

Power Conversion Systems

Power Supplies | Converters | Inverters | Chargers | Systems





	Page
COMPANY PROFILE	3
LOW POWER CONVERTERS FROM 100W TO 7.5KW, SWITCHMODE	9
DC/DC Converters, AC/DC Power Supplies & Battery Chargers	
Step-Up Converters	47
HIGH POWER CONVERTERS FROM 5 TO 40KW, SWITCHMODE	49
DC/DC Converters, AC/DC Power Supplies & Battery Chargers	
Step-Up Converters	83
INVERTERS FROM 200VA TO 45KVA	85
DC/AC Inverters & AC/AC Frequency Converters	
Static Switches	97
UPS Systems from 1000 to 2500VA	99
ACTIVE HARMONIC FILTERS	101
ELECTRONIC LOADS	105
THYRISTOR-CONTROLLED UNITS FROM 500W TO 500KW	109
AC/DC Power Supplies & Battery Chargers	
OPTIONS & ACCESSORIES	115
TECHNICAL NOTES	125
DESIGN SOLUTIONS	135



Dipl.-Ing.
Hansjürgen Schäfer
CEO

SCHAEFER being a wholly owned, privately run and assisted by a qualified, and experienced team of experts. SCHAEFER has grown in a controlled and sustainable manner to a dedicated workforce of over 200 people, who oversee the entire concept, design and manufacture of all of the SCHAEFER Product Portfolio. Stemming from more than 40 years experience, SCHAEFER Personnel can tap into a rich resource which can only be gained after detailed and in-depth consultation with Clients.

In his position as CEO, Dipl.-Ing. Hansjürgen Schäfer pursues this approved course of business management of continuously developing client relations and assistance. "Assisting our clients in the field of engineering, product utilization as well as in the area of flexible development of customized power supplies, we are pursuing a sustainable growth strategy. At the same time we are committing ourselves to our headquarter in Germany and are proud of our products "made in Germany"."

With its headquarter in South-Germany, a production facility in Ireland and sales offices in USA and UAE as well as numerous representatives, SCHAEFER possesses a comprehensive worldwide sales network.

Furthermore SCHAEFER clients benefit from these engineering skills through an optimized solution tailored, if necessary, to the needs and parameters of their projects which can be equipped with numerous additional options.

„In this context, being client orientated is our main priority. We are pleased to support you to tap the full potential of the SCHAEFER product range from 100W to 500kW. With pleasure we also compile for you a customised solution because you come first with us. Our purpose is to offer you high-quality power supplies with proven technology because we appreciate the importance of our products for your application.“



Germany



USA



UAE

Worldwide network of branch offices & representatives

SCHAEFER enables to support your needs with the best resources around the world.



Maintaining the ability to design & manufacture in house generates a large degree of flexibility. The SCHAEFER Client profits from these engineering skills through an optimised solution tailored to the needs and parameters of the Project.

Immediate proximity also generates the free flowing information path, which is the production and development area, along with the testing and customer support area being all under the same roof. This enhances the SCHAEFER Teams ability to react to exacting demands with ease. Fruits of this labour are to be seen throughout the world in a variety of fields such as:

- Rail & Automotive Industry
- Power Generation Plants
- Oil & Gas Industry
- Chemical Industry
- Industrial Automation
- Military Industry
- Building Security
- Integrated Airport Solutions

Development guidelines, arduous selection of industrial components regarding their load criteria and temperature performance as well as many test procedures during all steps of production ensure the highest product quality. In addition, Schaefer pursues a full supplier management according to ISO 9001 which guarantees permanent improvement of the products especially within the turbulent market of electronic components.

On demand, SCHAEFER can also provide additional customer specified tests in cooperation with external test laboratories.



Innovation
made in Germany



Be they on shore or off shore, stationary or mobile, land, air or marine based. A system component or complete system, environmentally Hazardous area1, corrosive or simply Industrial, there is a SCHAEFER Power Solution to fit the specified parameters.



System Design & integration



Installation of a 360kW expandable power supply system within a container for mineral exploration on vessel



Container ready for shipment



On board installation

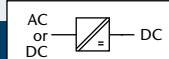

DC / DC Converters, AC / DC Power Supplies & Battery Chargers

- **DC Input voltage:** 10 - 800V DC
- **AC Input voltage:** 115 / 230V AC, single phase (with or without PFC) or 200 / 400 / 480V AC, three phases
- **AC Input frequency:** with PFC 47 - 65Hz, without PFC 47 - 400Hz
- **Output voltage:** 5 / ... / 400V DC
- **Output current:** up to 500A
- **Output power:** 100W - 7.5kW

Features

- Input / Output isolation
- Continuous short circuit protection
- Overvoltage protection with auto restart
- Operational from - 40 to +75 °C
- Industrial grade components
- Compact and robust design
- Natural convection (except for series C56xx and C57xx)



Specifications

Input

Voltage range	unit switches off at under- and overvoltage
No-load input power	5 - 6W typical except for series 4800, 5600/5700
Inrush current	AC input: limited by thermistor
Hold-up time	AC input: 10ms typical @ nom. input voltage (for series 4800: 5ms typical)
Immunity	acc. to EN 61000-6-2

Output

DC output voltages	5	9	12	15	24	28
	48	60	110	200	220	400
Line regulation (±10%)	0.1%					
Load regulation (10-90%)	0.2%					
Load transient (10-90-10%)	6 % typical					
Response time to ±1 %	2 - 3 ms					
Turn-on rise time	Soft-start, 100 ms typical					
Ripple	≤ 1% + 30 mV p-p					
Overload protection	current limited to 105-110% of I _{nom}					
Overvoltage protection	OVP switches off module with automatic return to operation					
Remote sense	standard for all series except for B / BP series; up to 10% of U _{nom} for output < 60V DC, up to 6V for output > 60V DC					

General

Efficiency	80 - 92% typical
Operating temperature	-20 to +75 °C (optional: -40 to +75 °C)
Load derating	2.5%/°C above + 55 °C
Storage temperature	-40 to + 85 °C
Cooling	☐ = natural convection ⊙ = increased air flow recommended ✱ = incl. temperature controlled fans (details see page 131)
Humidity	up to 95 % RH, non-condensing
Temperature coefficient	0.02 % / °C typical
Safety / Construction	acc. to EN 60950-1 / EN 50178
Protection category	IP20 acc. to EN 60529, NEMA or others upon request
EMI	acc. to EN 61000-6-4, class A, optionally class B
MTBF	100,000 - 140,000h @ 40 °C acc. to MIL - HDBK - 217E (notice 1)
Connectors	H15 acc. to DIN 41612 (details see page 132) and high current connectors for I > 50 A, or terminals / bolts / bars

Options (details see page 115)

Input

- Inrush current limiting
- Reverse polarity protection for DC input
- Autoranging for 115 / 230 VAC input

Output

- Decoupling diode for redundant / parallel operation
- Active current sharing for parallel operation
- Remote on / off (inhibit)

Signals

- via relay contacts
- Power ok (input)
 - DC ok (output)

Monitoring

- of input / output voltage or current via
- analog signal
 - interface card RS232 or CAN Bus (external)

Programming

- of output voltage or current via
- potentiometer
 - analog signal
 - interface card RS232 or CAN Bus (external)

Programming of battery chargers

- Temperature compensated charging voltage
- Automatic / manual selection of charging characteristic (external)

Mechanics / environment:

- 19" sub-rack for eurocassette, refer to page 121
- Wall mount
- Chassis mount
- DIN rail mount
- Increased mechanical strength
- Tropical protection
- Extended temperature range to -40 °C



Selector Guide

Series	Output Power					DC input								AC input			Nominal DC output voltage											Package					Cooling		Page				
	100 – 200 W	200 – 600 W	600 – 1600 W	1.6 – 4 kW	4 – 7.5 kW	[V]	10 - 16 V	18 - 36 V	36 - 75 V	45 - 90 V	80 - 160 V	160 - 320 V	320 - 380 V	320 - 640 V	450 - 800 V	1-phase	1-phase with PFC	3-phase	[V]	5 V	9 V	12 V	15 V	24 V	28 V	48 V	60 V	110 V	200 V	220 V	400 V	Euro-cassette for 19" Rack mount Height [U]	19" Plug-in module Height [U]	Wall mount		Chassis mount	DIN rail mount	Natural convection	Fan cooled
CH/CP/BP 200	100 – 150 W					18 – 320										■			5 / 9 / ... / 60												3			■	■	■			13
C/B 1200	120 – 200 W					10 – 380										■			5 / 9 / ... / 220												6		■	■		■			15
C/B 500	180 – 250 W					10 – 380										■		■	5 / 9 / ... / 220												3		■	■	■	■			17
S 600	200 – 350 W					10 – 380										■		■	5 / 9 / ... / 220												3		■	■	■	■			19
C/B 1300	250 – 400 W					10 – 380										■			5 / 9 / ... / 220												6		■	■		■			21
C/B 2500	300 – 400 W					18 – 380										■		■	5 / 9 / ... / 220												3		■	■		■			23
C/B 600	300 – 500 W					10 – 380										■		■	5 / 9 / ... / 220												3		■	■	■	■			25
C/B 1500	400 – 600 W					10 – 380										■		■	5 / 9 / ... / 400												6		■	■		■			27
C/B 2600	650 – 800 W					18 – 380										■		■	5 / 9 / ... / 220												3		■	■		■			29
C/B 3500	700 – 850 W					18 – 640										■		■	5 / 9 / ... / 400												6		■	■		■			31
C/B 3700	1000 – 1250 W					18 – 640										■		■	5 / 9 / ... / 400												6		■	■		■			33
C/B 4500	900 – 1600 W					10 – 800										■		■	9 / 12 / ... / 400												6		■	■		■			35
C/B 3600	1.4 – 1.7 kW					18 – 800										■		■	5 / 9 / ... / 400												6		■			■			37
C/CP/B/BP 4700	1.2 – 2.5 kW					10 – 800										■	■	■	5 / 9 / ... / 400												6		■	■		■			39
C/B 3800	2 – 2.5 kW					18 – 800										■		■	12 / 15 / ... / 400												6		■			■			41
C/B 4800	2.5 – 5 kW					10 – 800										■		■	12 / 15 / ... / 400												6		■			■			43
C 5600/5700	2.5 – 7.5 kW					10 – 80													5 / 9 / ... / 400												6					■			45
Step-Up Converters	100 W – 7.5 kW					10 – 400													10 / ... / 400												3 / 6	depending on module						47	

Further Information

Order example

Assistance in table use:

- 1 Select the column for input voltage range.
- 2 Select the row for the appropriate output voltage.
- 3 The intersection of both results in the module required.

For example:

- 1 input voltage = 48 VDC
- 2 output voltage = 12 VDC @ 12 A
- 3 results in a CH 232 module.

	Input VDC					Output VDC		
	18–36 VDC	36–75 VDC	45–90 VDC	80–160 VDC	160–320 VDC	Output Amps	Adj.	Range
CH 220	CH 230	CH 240	CH 250	CH 270	20	5	4.5 – 5.5	
CH 221	CH 231	CH 241	CH 251	CH 271	15	9	8 – 10	
CH 222	CH 232	CH 242	CH 252	CH 272	12	12	11 – 13	
CH 223	CH 233	CH 243	CH 253	CH 273	10	15	14 – 16	
...	
CH 227	CH 237	CH 247	CH 257	CH 277	1.2	110	100 – 130	
CH 228	CH 238	CH 248	CH 258	CH 278	0.6	220	200 – 250	

Conversion table

Height: 1 U = 44.45 mm
 1 U = 1.75"
 Width: 1 TE = 5.08 mm
 1 TE = 0.2"
 1" = 25.4 mm
 19" = 483 mm
 Weight: 1 kg = 2.2 lbs

Conversion diagram °C > °F

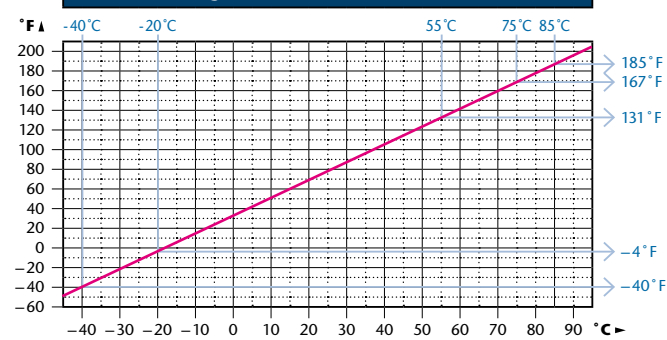

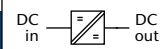

DC / DC Converters

▶ 150 W						Cooling	Output VDC	
Input VDC							Adj.	Range
18–36 VDC	36–75 VDC	45–90 VDC	80–160 VDC	160–320 VDC	Output Amps			
CH 220	CH 230	CH 240	CH 250	CH 270	20	Natural convection	5	4.5– 5.5
CH 221	CH 231	CH 241	CH 251	CH 271	15		9	8– 10
CH 222	CH 232	CH 242	CH 252	CH 272	12	Natural convection	12	11– 13
CH 223	CH 233	CH 243	CH 253	CH 273	10		15	14– 16
CH 224	CH 234	CH 244	CH 254	CH 274	6	Natural convection	24	23– 26
CH 225	CH 235	CH 245	CH 255	CH 275	5		28	26– 30
CH 229	CH 239	CH 249	CH 259	CH 279	3	Natural convection	48	45– 55
CH 226	CH 236	CH 246	CH 256	CH 276	2.3		60	58– 68

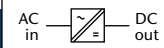

AC / DC Power Supplies

▶ 150 W				
Input VAC, 1-Phase		Cooling	Output VDC	
100–240 V ±10 %	Output Amps		Adj.	Range
CP 290	20	Natural convection	5	4.5– 5.5
CP 291	15		9	8– 10
CP 292	12	Natural convection	12	11– 13
CP 293	10		15	14– 16
CP 294	6	Natural convection	24	23– 26
CP 295	5		28	26– 30
CP 299	3	Natural convection	48	45– 55
CP 296	2.3		60	58– 68

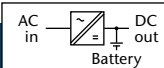

Battery Chargers

▶ 150 W				
Input VAC, 1-Phase		Cooling	Output VDC	
100–240 V 10 %	Output Amps		Nom. Battery Voltage	Range
BP 291	10	Natural convection	12	12– 16
BP 292	5		24	24– 32
BP 294	2.6	Natural convection	48	48– 64
BP 296	2		60	60– 80

Series specific information

Input

- Protection: by internal fuse
- Switch-on time: 250ms typical
- Power factor correction for CP/BP series acc. to EN 61000-3-2, class D

Output

- Response time to ±1 %: 1ms typical
- Remote sense: standard for CH/ CP series, up to 10% of U_{nom} for output <40V DC, up to 4V for output >40V DC
- Active current sharing for parallel operation
- Charger control: acc. to IU characteristics
- DC ok signal via open collector

General

- EMI: acc. to EN 55022, class B

Options

The number of options per module is restricted to input, output and mechanics/ environments (see page 10).

= natural convection



3U

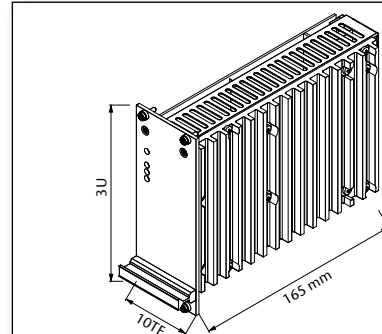

Standard
Eurocassette (pluggable module for 19" sub-rack) approx. 0.7 kg

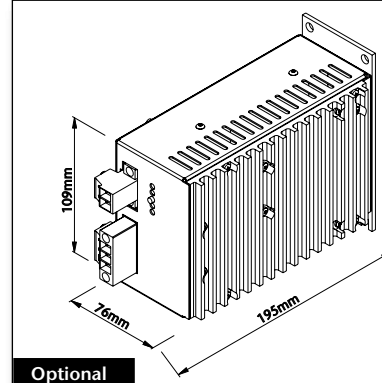

Optional
Chassis mount approx. 1.05 kg

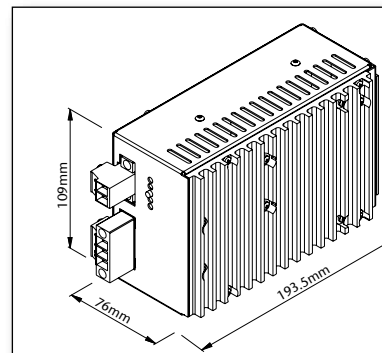

Optional
DIN rail mount approx. 1.0 kg



DC / DC Converters

▶ 120 W		▶ 150 W		▶ 200 W						Cooling	Output VDC	
Input VDC											Adj.	Range
10-16 VDC	Output Amps	18-36 VDC	Output Amps	36-75 VDC	45-90 VDC	80-160 VDC	160-320 VDC	320-380 ¹⁾ VDC	Output Amps			
C 1200	20	C 1220	25	C 1230	C 1240	C 1250	C 1270	C 1280 Z	30	5	4.5 - 5.5	
C 1201	12	C 1221	15	C 1231	C 1241	C 1251	C 1271	C 1281 Z	18	9	8 - 10	
C 1202	10	C 1222	12.5	C 1232	C 1242	C 1252	C 1272	C 1282 Z	15	12	11 - 13	
C 1203	8	C 1223	10	C 1233	C 1243	C 1253	C 1273	C 1283 Z	12	15	14 - 16	
C 1204	5	C 1224	6	C 1234	C 1244	C 1254	C 1274	C 1284 Z	7.5	24	23 - 26	
C 1205	4	C 1225	5	C 1235	C 1245	C 1255	C 1275	C 1285 Z	6.5	28	26 - 30	
C 1209	2.4	C 1229	3	C 1239	C 1249	C 1259	C 1279	C 1289 Z	3.6	48	45 - 55	
C 1206	2	C 1226	2.5	C 1236	C 1246	C 1256	C 1276	C 1286 Z	3	60	58 - 68	
C 1207	1	C 1227	1.2	C 1237	C 1247	C 1257	C 1277	C 1287 Z	1.5	110	100 - 130	
C 1208	0.5	C 1228	0.6	C 1238	C 1248	C 1258	C 1278	C 1288 Z	0.8	220	200 - 250	

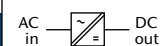

AC / DC Power Supplies

▶ 200 W				Cooling	Output VDC	
Input VAC, 1-Phase					Adj.	Range
115 ±20%	230 ^{+15%} / _{-20%}	115 ±20% / 230 ^{+15%} / _{-20%}	Output Amps			
C 1260	C 1280	C 1290	30	5	4.5 - 5.5	
C 1261	C 1281	C 1291	18	9	8 - 10	
C 1262	C 1282	C 1292	15	12	11 - 13	
C 1263	C 1283	C 1293	12	15	14 - 16	
C 1264	C 1284	C 1294	7.5	24	23 - 26	
C 1265	C 1285	C 1295	6.5	28	26 - 30	
C 1269	C 1289	C 1299	3.6	48	45 - 55	
C 1266	C 1286	C 1296	3	60	58 - 68	
C 1267	C 1287	C 1297	1.5	110	100 - 130	
C 1268	C 1288	C 1298	0.8	220	200 - 250	

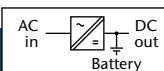

Battery Chargers

▶ 200 W				Cooling	Output VDC	
Input VAC, 1-Phase					Nom. Battery Voltage	Range
115 ±20%	230 ^{+15%} / _{-20%}	115 ±20% / 230 ^{+15%} / _{-20%}	Output Amps			
B 1261	B 1281	B 1291	12	12	12 - 16	
B 1262	B 1282	B 1292	6	24	24 - 32	
B 1264	B 1284	B 1294	3	48	48 - 64	
B 1266	B 1286	B 1296	2.6	60	60 - 80	
B 1267	B 1287	B 1297	1.4	110	110 - 145	
B 1268	B 1288	B 1298	0.7	220	220 - 290	

Series specific information

Input

■ Switch-on time: 500ms typical

¹⁾ Input supply from PFC also suitable

☰ = natural convection

6U

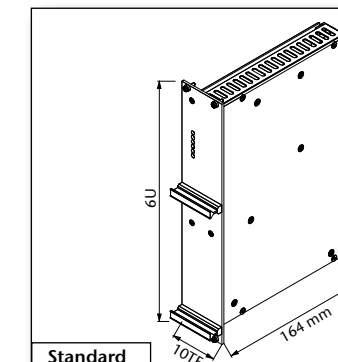

Standard

Eurocassette (pluggable module for 19" sub-rack) approx. 1.7 kg

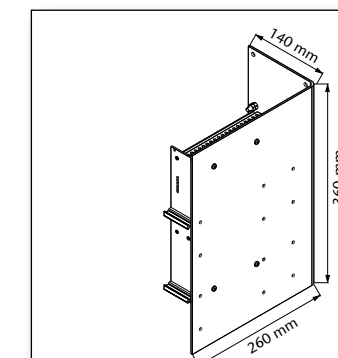

Optional

Wall mount approx. 4.7 kg

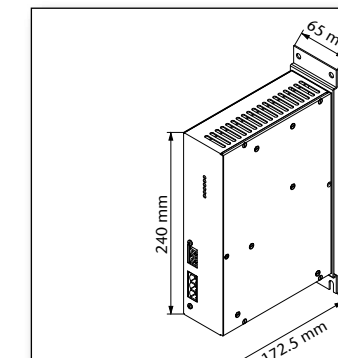

Optional

Chassis mount approx. 2.1 kg

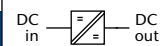

DC / DC Converters

▶ 180 W		▶ 200 W		▶ 250 W						Cooling	Output VDC	
Input VDC											Adj.	Range
10-16 VDC	Output Amps	18-36 VDC	Output Amps	36-75 VDC	45-90 VDC	80-160 VDC	160-320 VDC	320-380 ¹⁾ VDC	Output Amps			
C 500	25	C 520	30	C 530	C 540	C 550	C 570	C 580 Z	35	5	4.5 - 5.5	
C 501	17	C 521	20	C 531	C 541	C 551	C 571	C 581 Z	25	9	8 - 10	
C 502	14	C 522	16	C 532	C 542	C 552	C 572	C 582 Z	20	12	11 - 13	
C 503	11	C 523	13	C 533	C 543	C 553	C 573	C 583 Z	16	15	14 - 16	
C 504	7	C 524	8	C 534	C 544	C 554	C 574	C 584 Z	10	24	23 - 26	
C 505	6	C 525	7	C 535	C 545	C 555	C 575	C 585 Z	8.5	28	26 - 30	
C 509	3.5	C 529	4	C 539	C 549	C 559	C 579	C 589 Z	4.5	48	45 - 55	
C 506	3	C 526	3.5	C 536	C 546	C 556	C 576	C 586 Z	3.7	60	58 - 68	
C 507	1.5	C 527	1.8	C 537	C 547	C 557	C 577	C 587 Z	2	110	100 - 130	
C 508	0.8	C 528	0.9	C 538	C 548	C 558	C 578	C 588 Z	1	220	200 - 250	

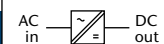

AC / DC Power Supplies

▶ 250 W						Cooling	Output VDC	
Input VAC, 1-Phase			Input VAC, 3-Phase	Output Amps	Adj.		Range	
115 ±20%	230 ^{+15%} / _{-20%}	115 ±20% / 230 ^{+15%} / _{-20%}	3x200 ^{+15%} / _{-20%}					
C 560	C 580	C 590	C 560 V	35	5	4.5 - 5.5		
C 561	C 581	C 591	C 561 V	25	9	8 - 10		
C 562	C 582	C 592	C 562 V	20	12	11 - 13		
C 563	C 583	C 593	C 563 V	16	15	14 - 16		
C 564	C 584	C 594	C 564 V	10	24	23 - 26		
C 565	C 585	C 595	C 565 V	8.5	28	26 - 30		
C 569	C 589	C 599	C 569 V	4.5	48	45 - 55		
C 566	C 586	C 596	C 566 V	3.7	60	58 - 68		
C 567	C 587	C 597	C 567 V	2	110	100 - 130		
C 568	C 588	C 598	C 568 V	1	220	200 - 250		

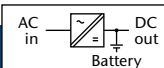

Battery Chargers

▶ 250 W						Cooling	Output VDC	
Input VAC, 1-Phase			Input VAC, 3-Phase	Output Amps	Nom. Battery Voltage		Range	
115 ±20%	230 ^{+15%} / _{-20%}	115 ±20% / 230 ^{+15%} / _{-20%}	3x200 ^{+15%} / _{-20%}					
B 561	B 581	B 591	B 561 V	16	12	12 - 16		
B 562	B 582	B 592	B 562 V	8	24	24 - 32		
B 564	B 584	B 594	B 564 V	4	48	48 - 64		
B 566	B 586	B 596	B 566 V	3.2	60	60 - 80		
B 567	B 587	B 597	B 567 V	2	110	110 - 145		
B 568	B 588	B 598	B 568 V	1	220	220 - 290		

Series specific information

Input

- Switch-on time: 1-2s

¹⁾ Input supply from PFC also suitable

= natural convection

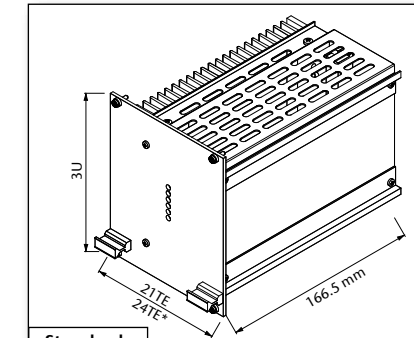

Standard
Eurocassette (pluggable module for 19" sub-rack)
*) applicable to 5 V output models
approx. 1.7 kg

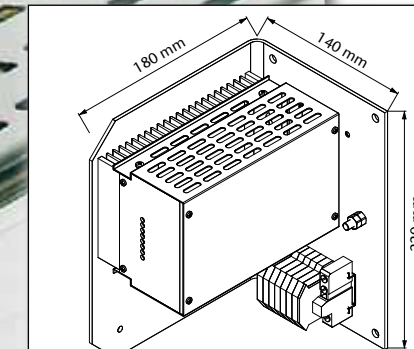

Optional
Wall mount
approx. 3.2 kg

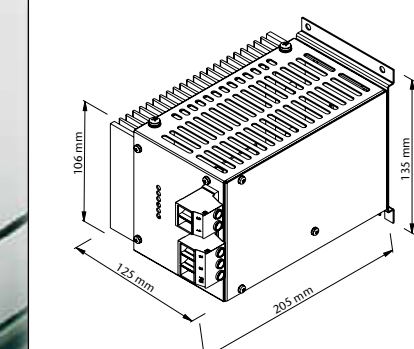

Optional
Chassis mount
approx. 2.1 kg

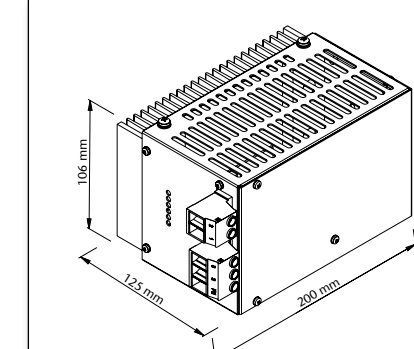

Optional
DIN rail mount
approx. 2.05 kg



DC / DC Converters

▶ 200 W		▶ 300 W		▶ 350 W						Cooling	Output VDC	
Input VDC											Adj.	Range
10–16 VDC	Output Amps	18–36 VDC	Output Amps	36–75 VDC	45–90 VDC	80–160 VDC	160–320 VDC	320–380 ¹⁾ VDC	Output Amps			
S 600	30	S 620	50	S 630	S 640	S 650	S 670	S 680 Z	50	5	4.5 – 5.5	
S 601	20	S 621	30	S 631	S 641	S 651	S 671	S 681 Z	32	9	8 – 10	
S 602	15	S 622	24	S 632	S 642	S 652	S 672	S 682 Z	26	12	11 – 13	
S 603	12	S 623	20	S 633	S 643	S 653	S 673	S 683 Z	22	15	14 – 16	
S 604	8	S 624	12	S 634	S 644	S 654	S 674	S 684 Z	14	24	23 – 26	
S 605	7	S 625	10	S 635	S 645	S 655	S 675	S 685 Z	12	28	26 – 30	
S 609	4.4	S 629	6	S 639	S 649	S 659	S 679	S 689 Z	6.5	48	45 – 55	
S 606	3.6	S 626	5	S 636	S 646	S 656	S 676	S 686 Z	5.2	60	58 – 68	
S 607	1.8	S 627	2.5	S 637	S 647	S 657	S 677	S 687 Z	3	110	100 – 130	
S 608	0.9	S 628	1.25	S 638	S 648	S 658	S 678	S 688 Z	1.5	220	200 – 250	

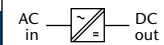

AC / DC Power Supplies

▶ 350 W								Cooling	Output VDC	
Input VAC, 1-Phase				Input VAC, 3-Phase	Output Amps	Adj.	Range			
115 ±20%	230 ^{+15%} / _{-20%}	115 ±20% / 230 ^{+15%} / _{-20%}	3x200 ^{+15%} / _{-20%}							
S 660	S 680	S 690	S 660 V	50	5	4.5 – 5.5				
S 661	S 681	S 691	S 661 V	32	9	8 – 10				
S 662	S 682	S 692	S 662 V	26	12	11 – 13				
S 663	S 683	S 693	S 663 V	22	15	14 – 16				
S 664	S 684	S 694	S 664 V	14	24	23 – 26				
S 665	S 685	S 695	S 665 V	12	28	26 – 30				
S 669	S 689	S 699	S 669 V	6.5	48	45 – 55				
S 666	S 686	S 696	S 666 V	5.2	60	58 – 68				
S 667	S 687	S 697	S 667 V	3	110	100 – 130				
S 668	S 688	S 698	S 668 V	1.5	220	200 – 250				

3U

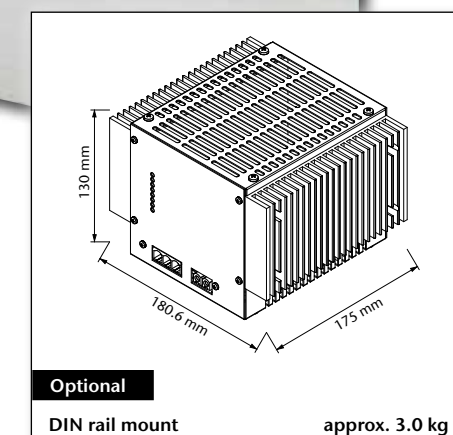
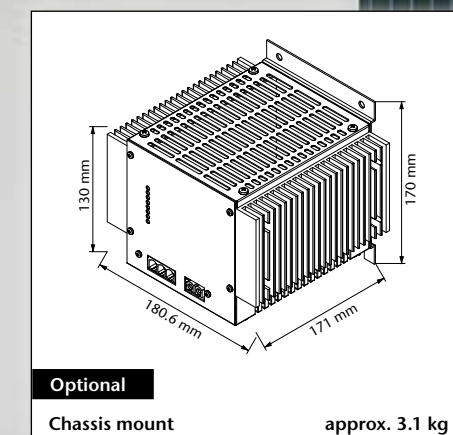
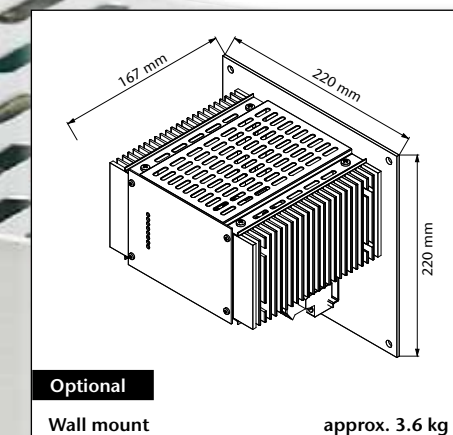
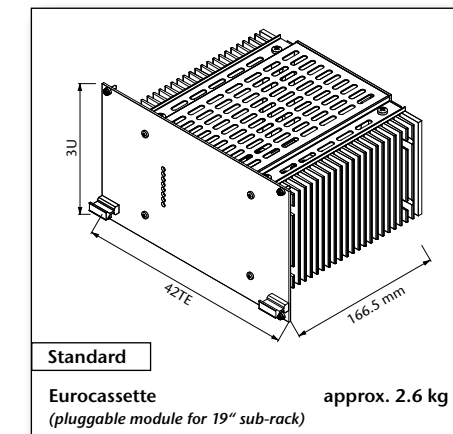

Series specific information

Input

- Switch-on time: 500ms typical

¹⁾ Input supply from PFC also suitable

= natural convection



DC / DC Converters

▶ 250 W		▶ 300 W		▶ 400 W						Cooling	Output VDC	
Input VDC											Adj.	Range
10–16 VDC	Output Amps	18–36 VDC	Output Amps	36–75 VDC	45–90 VDC	80–160 VDC	160–320 VDC	320–380 ¹⁾ VDC	Output Amps			
C 1300	35	C 1320	45	C 1330	C 1340	C 1350	C 1370	C 1380 Z	50	5	4.5– 5.5	
C 1301	24	C 1321	30	C 1331	C 1341	C 1351	C 1371	C 1381 Z	35	9	8– 10	
C 1302	20	C 1322	25	C 1332	C 1342	C 1352	C 1372	C 1382 Z	30	12	11– 13	
C 1303	16	C 1323	21	C 1333	C 1343	C 1353	C 1373	C 1383 Z	25	15	14– 16	
C 1304	10	C 1324	13	C 1334	C 1344	C 1354	C 1374	C 1384 Z	15	24	23– 26	
C 1305	8.5	C 1325	11	C 1335	C 1345	C 1355	C 1375	C 1385 Z	13	28	26– 30	
C 1309	5	C 1329	6	C 1339	C 1349	C 1359	C 1379	C 1389 Z	7.3	48	45– 55	
C 1306	4	C 1326	5	C 1336	C 1346	C 1356	C 1376	C 1386 Z	6	60	58– 68	
C 1307	2	C 1327	2.5	C 1337	C 1347	C 1357	C 1377	C 1387 Z	3	110	100– 130	
C 1308	1	C 1328	1.25	C 1338	C 1348	C 1358	C 1378	C 1388 Z	1.5	220	200– 250	

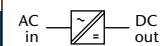

AC / DC Power Supplies

▶ 400 W				Cooling	Output VDC	
Input VAC, 1-Phase					Adj.	Range
115 ±20%	230 ^{+15%} / _{-20%}	115 ±20% / 230 ^{+15%} / _{-20%}	Output Amps			
C 1360	C 1380	C 1390	50	5	4.5– 5.5	
C 1361	C 1381	C 1391	35	9	8– 10	
C 1362	C 1382	C 1392	30	12	11– 13	
C 1363	C 1383	C 1393	25	15	14– 16	
C 1364	C 1384	C 1394	15	24	23– 26	
C 1365	C 1385	C 1395	13	28	26– 30	
C 1369	C 1389	C 1399	7.3	48	45– 55	
C 1366	C 1386	C 1396	6	60	58– 68	
C 1367	C 1387	C 1397	3	110	100– 130	
C 1368	C 1388	C 1398	1.5	220	200– 250	



Battery Chargers

▶ 400 W				Cooling	Output VDC	
Input VAC, 1-Phase					Nom. Battery Voltage	Range
115 ±20%	230 ^{+15%} / _{-20%}	115 ±20% / 230 ^{+15%} / _{-20%}	Output Amps			
B 1361	B 1381	B 1391	25	12	12– 16	
B 1362	B 1382	B 1392	12	24	24– 32	
B 1364	B 1384	B 1394	6	48	48– 64	
B 1366	B 1386	B 1396	4.5	60	60– 80	
B 1367	B 1387	B 1397	2.7	110	110– 145	
B 1368	B 1388	B 1398	1.4	220	220– 290	

Series specific information

Input

■ Switch-on time: 500ms typical

¹⁾ Input supply from PFC also suitable

☼ = natural convection



6U

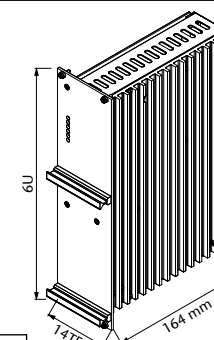

Standard

Eurocassette (pluggable module for 19" sub-rack) approx. 2.0 kg

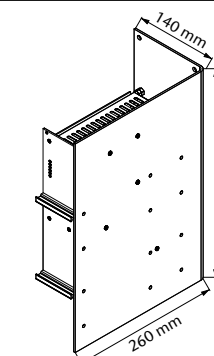

Optional

Wall mount approx. 5.0 kg

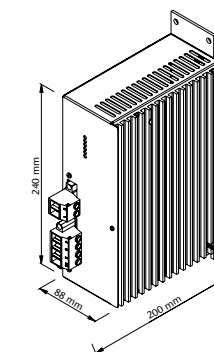

Optional

Chassis mount approx. 2.4 kg



DC / DC Converters

▶ 300 W				▶ 400 W				Cooling	Output VDC	
Input VDC									Adj.	Range
18–36 VDC	Output Amps	36–75 VDC	45–90 VDC	80–160 VDC	160–320 VDC	320–380 ¹⁾ VDC	Output Amps			
C 2520	45	C 2530	C 2540	C 2550	C 2570	C 2580 Z	55	5	4.5– 5.5	
C 2521	27	C 2531	C 2541	C 2551	C 2571	C 2581 Z	32	9	8– 10	
C 2522	23	C 2532	C 2542	C 2552	C 2572	C 2582 Z	27	12	11– 13	
C 2523	20	C 2533	C 2543	C 2553	C 2573	C 2583 Z	23	15	14– 16	
C 2524	13	C 2534	C 2544	C 2554	C 2574	C 2584 Z	15	24	23– 26	
C 2525	11	C 2535	C 2545	C 2555	C 2575	C 2585 Z	13	28	26– 30	
C 2529	6	C 2539	C 2549	C 2559	C 2579	C 2589 Z	7.2	48	45– 55	
C 2526	5	C 2536	C 2546	C 2556	C 2576	C 2586 Z	6	60	58– 68	
C 2527	2.5	C 2537	C 2547	C 2557	C 2577	C 2587 Z	3	110	100– 130	
C 2528	1.3	C 2538	C 2548	C 2558	C 2578	C 2588 Z	1.6	220	200– 250	

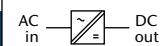

AC / DC Power Supplies

▶ 400 W								Cooling	Output VDC	
Input VAC, 1-Phase				Input VAC, 3-Phase	Output Amps	Adj.	Range			
115 ±20%	230 ^{+15%} _{-20%}	115 ±20% / 230 ^{+15%} _{-20%}	3x200 ^{+15%} _{-20%}							
C 2560	C 2580	C 2590	C 2560 V	55	5	4.5– 5.5				
C 2561	C 2581	C 2591	C 2561 V	32	9	8– 10				
C 2562	C 2582	C 2592	C 2562 V	27	12	11– 13				
C 2563	C 2583	C 2593	C 2563 V	23	15	14– 16				
C 2564	C 2584	C 2594	C 2564 V	15	24	23– 26				
C 2565	C 2585	C 2595	C 2565 V	13	28	26– 30				
C 2569	C 2589	C 2599	C 2569 V	7.2	48	45– 55				
C 2566	C 2586	C 2596	C 2566 V	6	60	58– 68				
C 2567	C 2587	C 2597	C 2567 V	3	110	100– 130				
C 2568	C 2588	C 2598	C 2568 V	1.6	220	200– 250				

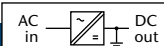

Battery Chargers

▶ 400 W								Cooling	Output VDC	
Input VAC, 1-Phase				Input VAC, 3-Phase	Output Amps	Nom. Battery Voltage	Range			
115 ±20%	230 ^{+15%} _{-20%}	115 ±20% / 230 ^{+15%} _{-20%}	3x200 ^{+15%} _{-20%}							
B 2561	B 2581	B 2591	B 2561 V	23	12	12– 16				
B 2562	B 2582	B 2592	B 2562 V	13	24	24– 32				
B 2564	B 2584	B 2594	B 2564 V	6.2	48	48– 64				
B 2566	B 2586	B 2596	B 2566 V	5.1	60	60– 80				
B 2567	B 2587	B 2597	B 2567 V	2.8	110	110– 145				
B 2568	B 2588	B 2598	B 2568 V	1.4	220	220– 290				

Series specific information

Input

- Switch-on time: 500ms typical
- ¹⁾ Input supply from PFC also suitable
- = natural convection

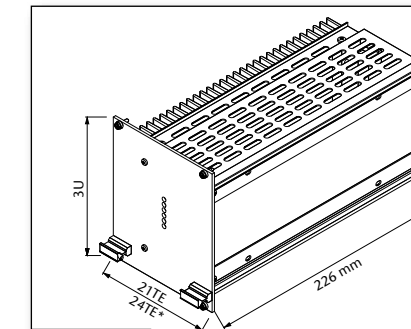

Standard
Eurocassette
(pluggable module for 19" sub-rack) **approx. 2.5 kg**
*) applicable to 5 V output models

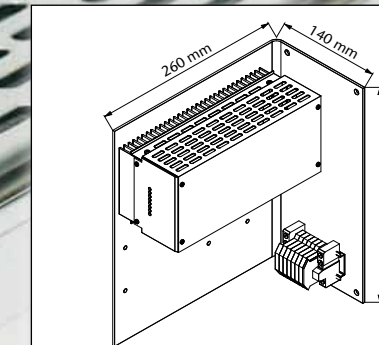

Optional
Wall mount **approx. 5.0 kg**

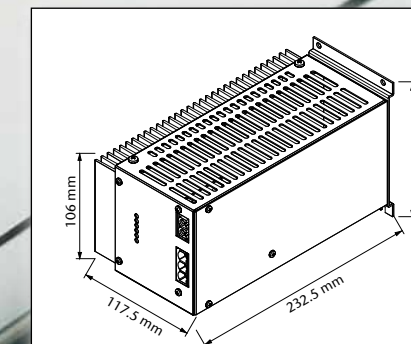

Optional
Chassis mount **approx. 3.0 kg**

3U





DC / DC Converters

▶ 300 W		▶ 450 W		▶ 500 W						Cooling	Output VDC	
Input VDC											Adj.	Range
10–16 VDC	Output Amps	18–36 VDC	Output Amps	36–75 VDC	45–90 VDC	80–160 VDC	160–320 VDC	320–380 ¹⁾ VDC	Output Amps			
C 600	50	C 620	70	C 630	C 640	C 650	C 670	C 680 Z	80	5	4.5– 5.5	
C 601	30	C 621	45	C 631	C 641	C 651	C 671	C 681 Z	50	9	8– 10	
C 602	25	C 622	35	C 632	C 642	C 652	C 672	C 682 Z	40	12	11– 13	
C 603	20	C 623	28	C 633	C 643	C 653	C 673	C 683 Z	32	15	14– 16	
C 604	12	C 624	18	C 634	C 644	C 654	C 674	C 684 Z	20	24	23– 26	
C 605	10	C 625	15	C 635	C 645	C 655	C 675	C 685 Z	17	28	26– 30	
C 609	6	C 629	8	C 639	C 649	C 659	C 679	C 689 Z	9	48	45– 55	
C 606	5	C 626	7	C 636	C 646	C 656	C 676	C 686 Z	7.5	60	58– 68	
C 607	2.5	C 627	3.5	C 637	C 647	C 657	C 677	C 687 Z	4	110	100– 130	
C 608	1.2	C 628	1.8	C 638	C 648	C 658	C 678	C 688 Z	2	220	200– 250	

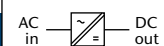

AC / DC Power Supplies

▶ 500 W						Cooling	Output VDC	
Input VAC, 1-Phase			Input VAC, 3-Phase	Output Amps	Adj.		Range	
115 ±20%	230 ^{+15%} _{-20%}	115 ±20% / 230 ^{+15%} _{-20%}	3x200 ^{+15%} _{-20%}					
C 660	C 680	C 690	C 660 V	80	5	4.5– 5.5		
C 661	C 681	C 691	C 661 V	50	9	8– 10		
C 662	C 682	C 692	C 662 V	40	12	11– 13		
C 663	C 683	C 693	C 663 V	32	15	14– 16		
C 664	C 684	C 694	C 664 V	20	24	23– 26		
C 665	C 685	C 695	C 665 V	17	28	26– 30		
C 669	C 689	C 699	C 669 V	9	48	45– 55		
C 666	C 686	C 696	C 666 V	7.5	60	58– 68		
C 667	C 687	C 697	C 667 V	4	110	100– 130		
C 668	C 688	C 698	C 668 V	2	220	200– 250		

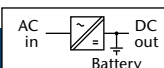

Battery Chargers

▶ 500 W						Cooling	Output VDC	
Input VAC, 1-Phase			Input VAC, 3-Phase	Output Amps	Nom. Battery Voltage		Range	
115 ±20%	230 ^{+15%} _{-20%}	115 ±20% / 230 ^{+15%} _{-20%}	3x200 ^{+15%} _{-20%}					
B 661	B 681	B 691	B 661 V	32	12	12– 16		
B 662	B 682	B 692	B 662 V	16	24	24– 32		
B 664	B 684	B 694	B 664 V	8	48	48– 64		
B 666	B 686	B 696	B 666 V	6.4	60	60– 80		
B 667	B 687	B 697	B 667 V	3.5	110	110– 145		
B 668	B 688	B 698	B 668 V	1.8	220	220– 290		

Series specific information

Input

- Switch-on time: 500ms typical

¹⁾ Input supply from PFC also suitable

= natural convection

3U

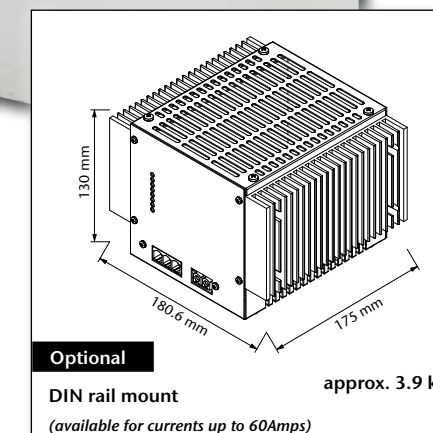
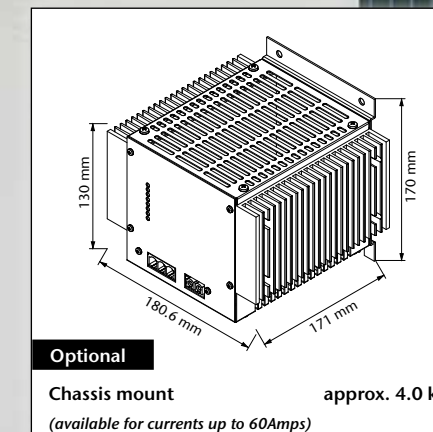
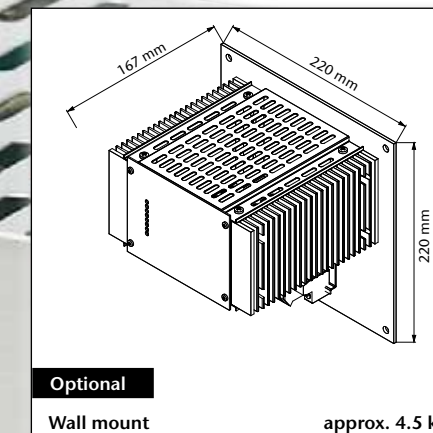
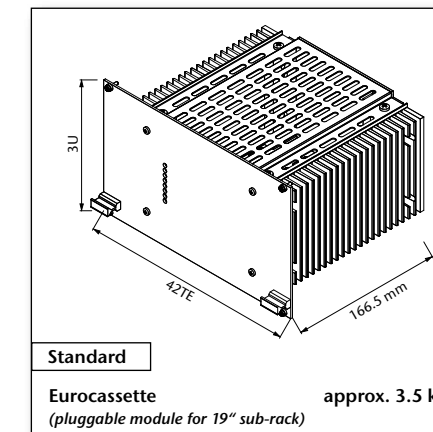



DC / DC Converters

▶ 400 W		▶ 500 W		▶ 600 W						Cooling	Output VDC	
Input VDC											Adj.	Range
10–16 VDC	Output Amps	18–36 VDC	Output Amps	36–75 VDC	45–90 VDC	80–160 VDC	160–320 VDC	320–380 ¹⁾ VDC	Output Amps			
C 1500	40	C 1520	60	C 1530	C 1540	C 1550	C 1570	C 1580 Z	80	5	4.5– 5.5	
C 1501	25	C 1521	38	C 1531	C 1541	C 1551	C 1571	C 1581 Z	50	9	8– 10	
C 1502	24	C 1522	33	C 1532	C 1542	C 1552	C 1572	C 1582 Z	42	12	11– 13	
C 1503	20	C 1523	25	C 1533	C 1543	C 1553	C 1573	C 1583 Z	34	15	14– 16	
C 1504	15	C 1524	18	C 1534	C 1544	C 1554	C 1574	C 1584 Z	23	24	23– 26	
C 1505	13	C 1525	15	C 1535	C 1545	C 1555	C 1575	C 1585 Z	20	28	26– 30	
C 1509	7	C 1529	8	C 1539	C 1549	C 1559	C 1579	C 1589 Z	11	48	45– 55	
C 1506	5.5	C 1526	6.5	C 1536	C 1546	C 1556	C 1576	C 1586 Z	9	60	58– 68	
C 1507	3	C 1527	3.3	C 1537	C 1547	C 1557	C 1577	C 1587 Z	4.5	110	100– 130	
C 1507 J	2	C 1527 J	2.5	C 1537 J	C 1547 J	C 1557 J	C 1577 J	C 1587 Z J	3	200	190– 200	
C 1508	1.4	C 1528	1.6	C 1538	C 1548	C 1558	C 1578	C 1588 Z	2.4	220	200– 250	
C 1508 J	1	C 1528 J	1.3	C 1538 J	C 1548 J	C 1558 J	C 1578 J	C 1588 Z J	1.5	400	380– 400	

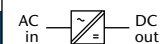

AC / DC Power Supplies

▶ 600 W						Cooling	Output VDC	
Input VAC, 1-Phase			Input VAC, 3-Phase	Output Amps	Adj.		Range	
115 ±20%	230 ^{+15%} _{-20%}	115 ±20% / 230 ^{+15%} _{-20%}	3x200 ^{+15%} _{-20%}					
C 1560	C 1580	C 1590	C 1560 V	80	5	4.5– 5.5		
C 1561	C 1581	C 1591	C 1561 V	50	9	8– 10		
C 1562	C 1582	C 1592	C 1562 V	42	12	11– 13		
C 1563	C 1583	C 1593	C 1563 V	34	15	14– 16		
C 1564	C 1584	C 1594	C 1564 V	23	24	23– 26		
C 1565	C 1585	C 1595	C 1565 V	20	28	26– 30		
C 1569	C 1589	C 1599	C 1569 V	11	48	45– 55		
C 1566	C 1586	C 1596	C 1566 V	9	60	58– 68		
C 1567	C 1587	C 1597	C 1567 V	4.5	110	100– 130		
C 1567 J	C 1587 J	C 1597 J	C 1567 V J	3	200	190– 200		
C 1568	C 1588	C 1598	C 1568 V	2.4	220	200– 250		
C 1568 J	C 1588 J	C 1598 J	C 1568 V J	1.5	400	380– 400		

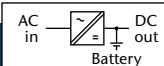

Battery Chargers

▶ 600 W						Cooling	Output VDC	
Input VAC, 1-Phase			Input VAC, 3-Phase	Output Amps	Nom. Battery Voltage		Range	
115 ±20%	230 ^{+15%} _{-20%}	115 ±20% / 230 ^{+15%} _{-20%}	3x200 ^{+15%} _{-20%}					
B 1561	B 1581	B 1591	B 1561 V	34	12	12– 16		
B 1562	B 1582	B 1592	B 1562 V	18	24	24– 32		
B 1564	B 1584	B 1594	B 1564 V	9	48	48– 64		
B 1566	B 1586	B 1596	B 1566 V	7.5	60	60– 80		
B 1567	B 1587	B 1597	B 1567 V	4	110	110– 145		
B 1568	B 1588	B 1598	B 1568 V	2	220	220– 290		

Series specific information

Input

- Switch-on time: 500ms typical

¹⁾ Input supply from PFC also suitable

= natural convection

6U

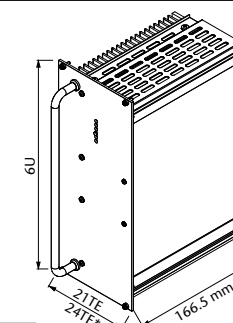

Standard
Eurocassette
(pluggable module for 19" sub-rack) approx. 3.3 kg
(*) applicable to 5 V output models

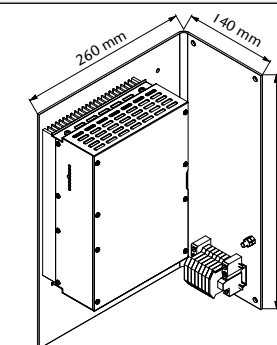

Optional
Wall mount approx. 6.3 kg

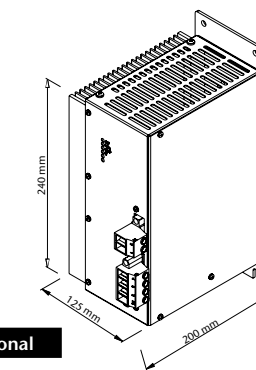

Optional
Chassis mount approx. 3.8 kg
(available for currents up to 60Amps)

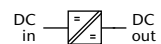

DC / DC Converters

▶ 650 W				▶ 800 W				Cooling	Output VDC	
Input VDC									Adj.	Range
18-36 VDC	Output Amps	36-75 VDC	45-90 VDC	80-160 VDC	160-320 VDC	320-380 ¹⁾ VDC	Output Amps			
C 2620	85	C 2630	C 2640	C 2650	C 2670	C 2680 Z	100	5	4.5- 5.5	
C 2621	65	C 2631	C 2641	C 2651	C 2671	C 2681 Z	75	9	8- 10	
C 2622	50	C 2632	C 2642	C 2652	C 2672	C 2682 Z	60	12	11- 13	
C 2623	42	C 2633	C 2643	C 2653	C 2673	C 2683 Z	50	15	14- 16	
C 2624	25	C 2634	C 2644	C 2654	C 2674	C 2684 Z	30	24	23- 26	
C 2625	22	C 2635	C 2645	C 2655	C 2675	C 2685 Z	27	28	26- 30	
C 2629	12	C 2639	C 2649	C 2659	C 2679	C 2689 Z	15	48	45- 55	
C 2626	10	C 2636	C 2646	C 2656	C 2676	C 2686 Z	12	60	58- 68	
C 2627	5	C 2637	C 2647	C 2657	C 2677	C 2687 Z	6.5	110	100- 130	
C 2628	2.5	C 2638	C 2648	C 2658	C 2678	C 2688 Z	3.2	220	200- 250	

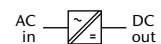

AC / DC Power Supplies

▶ 800 W						Cooling	Output VDC	
Input VAC, 1-Phase			Input VAC, 3-Phase	Output Amps	Adj.		Range	
115 ±20%	230 ^{+15%} _{-20%}	115 ±20% / 230 ^{+15%} _{-20%}	3x200 ^{+15%} _{-20%}					
C 2660	C 2680	C 2690	C 2660 V	100	5	4.5- 5.5		
C 2661	C 2681	C 2691	C 2661 V	75	9	8- 10		
C 2662	C 2682	C 2692	C 2662 V	60	12	11- 13		
C 2663	C 2683	C 2693	C 2663 V	50	15	14- 16		
C 2664	C 2684	C 2694	C 2664 V	30	24	23- 26		
C 2665	C 2685	C 2695	C 2665 V	27	28	26- 30		
C 2669	C 2689	C 2699	C 2669 V	15	48	45- 55		
C 2666	C 2686	C 2696	C 2666 V	12	60	58- 68		
C 2667	C 2687	C 2697	C 2667 V	6.5	110	100- 130		
C 2668	C 2688	C 2698	C 2668 V	3.2	220	200- 250		

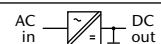

Battery Chargers

▶ 800 W						Cooling	Output VDC	
Input VAC, 1-Phase			Input VAC, 3-Phase	Output Amps	Nom. Battery Voltage		Range	
115 ±20%	230 ^{+15%} _{-20%}	115 ±20% / 230 ^{+15%} _{-20%}	3x200 ^{+15%} _{-20%}					
B 2661	B 2681	B 2691	B 2661 V	50	12	12- 16		
B 2662	B 2682	B 2692	B 2662 V	25	24	24- 32		
B 2664	B 2684	B 2694	B 2664 V	13	48	48- 64		
B 2666	B 2686	B 2696	B 2666 V	10	60	60- 80		
B 2667	B 2687	B 2697	B 2667 V	6	110	110- 145		
B 2668	B 2688	B 2698	B 2668 V	3	220	220- 290		

Series specific information

Input

- Switch-on time: 500ms typical
- ¹⁾ Input supply from PFC also suitable
- = natural convection
- = increased air flow recommended

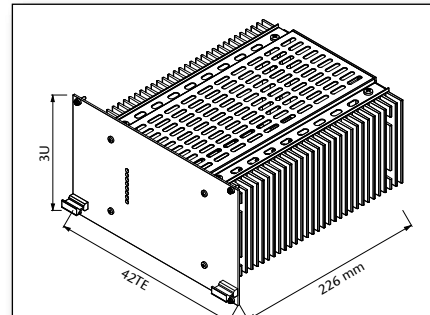

Standard
Eurocassette (pluggable module for 19" sub-rack) approx. 4.0 kg

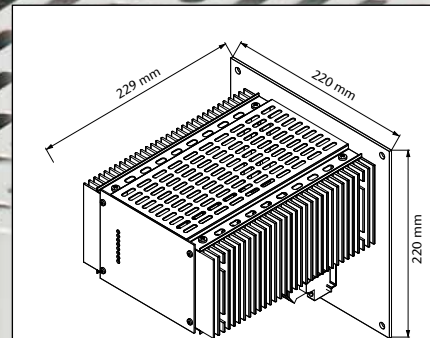

Optional
Wall mount approx. 6.0 kg

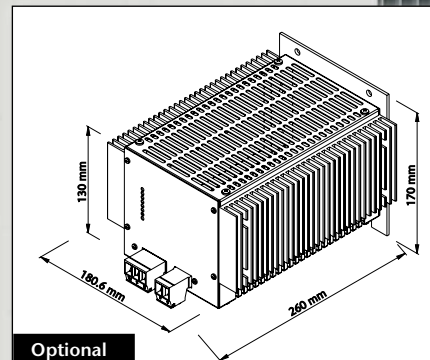

Optional
Chassis mount (available for currents up to 60Amps) approx. 4.6 kg

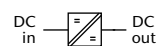

DC / DC Converters

▶ 700 W			▶ 850 W						Cooling	Output VDC	
Input VDC										Adj.	Range
18-36 VDC	Output Amps	36-75 VDC	45-90 VDC	80-160 VDC	160-320 VDC	320-380 ¹⁾ VDC	320-640 ²⁾ VDC	Output Amps			
C 3520	80	C 3530	C 3540	C 3550	C 3570	C 3580 Z	C 3570 G	100	☉	5	4.5- 5.5
C 3521	55	C 3531	C 3541	C 3551	C 3571	C 3581 Z	C 3571 G	65	☉	9	8- 10
C 3522	50	C 3532	C 3542	C 3552	C 3572	C 3582 Z	C 3572 G	56	☉	12	11- 13
C 3523	40	C 3533	C 3543	C 3553	C 3573	C 3583 Z	C 3573 G	45	☉	15	14- 16
C 3524	27	C 3534	C 3544	C 3554	C 3574	C 3584 Z	C 3574 G	30	☉	24	23- 26
C 3525	23	C 3535	C 3545	C 3555	C 3575	C 3585 Z	C 3575 G	27	☉	28	26- 30
C 3529	12	C 3539	C 3549	C 3559	C 3579	C 3589 Z	C 3579 G	14	☉	48	45- 55
C 3526	10	C 3536	C 3546	C 3556	C 3576	C 3586 Z	C 3576 G	12	☉	60	58- 68
C 3527	5.3	C 3537	C 3547	C 3557	C 3577	C 3587 Z	C 3577 G	6.5	☉	110	100- 130
C 3527 J	3.5	C 3537 J	C 3547 J	C 3557 J	C 3577 J	C 3587 ZJ	C 3577 GJ	4	☉	200	190- 200
C 3528	2.8	C 3538	C 3548	C 3558	C 3578	C 3588 Z	C 3578 G	3.5	☉	220	200- 250
C 3528 J	1.7	C 3538 J	C 3548 J	C 3558 J	C 3578 J	C 3588 ZJ	C 3578 GJ	2	☉	400	380- 400



AC / DC Power Supplies

▶ 850 W									Cooling	Output VDC	
Input VAC, 1-Phase			Input VAC, 3-Phase			Output Amps	Adj.	Range			
115 ±20%	230 ^{+15%} / _{-20%}	115 ±20% / 230 ^{+15%} / _{-20%}	3x200 ^{+15%} / _{-20%}	3x400 ^{+15%} / _{-20%}	3x480 ^{+10%} / _{-15%}						
C 3560	C 3580	C 3590	C 3560 V	C 3580 V	C 3590 V	100	☉	5	4.5- 5.5		
C 3561	C 3581	C 3591	C 3561 V	C 3581 V	C 3591 V	65	☉	9	8- 10		
C 3562	C 3582	C 3592	C 3562 V	C 3582 V	C 3592 V	56	☉	12	11- 13		
C 3563	C 3583	C 3593	C 3563 V	C 3583 V	C 3593 V	45	☉	15	14- 16		
C 3564	C 3584	C 3594	C 3564 V	C 3584 V	C 3594 V	30	☉	24	23- 26		
C 3565	C 3585	C 3595	C 3565 V	C 3585 V	C 3595 V	27	☉	28	26- 30		
C 3569	C 3589	C 3599	C 3569 V	C 3589 V	C 3599 V	14	☉	48	45- 55		
C 3566	C 3586	C 3596	C 3566 V	C 3586 V	C 3596 V	12	☉	60	58- 68		
C 3567	C 3587	C 3597	C 3567 V	C 3587 V	C 3597 V	6.5	☉	110	100- 130		
C 3567 J	C 3587 J	C 3597 J	C 3567 VJ	C 3587 VJ	C 3597 VJ	4	☉	200	190- 200		
C 3568	C 3588	C 3598	C 3568 V	C 3588 V	C 3598 V	3.5	☉	220	200- 250		
C 3568 J	C 3588 J	C 3598 J	C 3568 VJ	C 3588 VJ	C 3598 VJ	2	☉	400	380- 400		

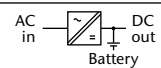

Battery Chargers

▶ 850 W									Cooling	Output VDC	
Input VAC, 1-Phase			Input VAC, 3-Phase			Output Amps	Nom. Battery Voltage	Range			
115 ±20%	230 ^{+15%} / _{-20%}	115 ±20% / 230 ^{+15%} / _{-20%}	3x200 ^{+15%} / _{-20%}	3x400 ^{+15%} / _{-20%}	3x480 ^{+10%} / _{-15%}						
B 3561	B 3581	B 3591	B 3561 V	B 3581 V	B 3591 V	50	☉	12	12- 16		
B 3562	B 3582	B 3592	B 3562 V	B 3582 V	B 3592 V	28	☉	24	24- 32		
B 3564	B 3584	B 3594	B 3564 V	B 3584 V	B 3594 V	15	☉	48	48- 64		
B 3566	B 3586	B 3596	B 3566 V	B 3586 V	B 3596 V	12	☉	60	60- 80		
B 3567	B 3587	B 3597	B 3567 V	B 3587 V	B 3597 V	7	☉	110	110- 145		
B 3568	B 3588	B 3598	B 3568 V	B 3588 V	B 3598 V	3.5	☉	220	220- 290		

Series specific information

Input

- Switch-on time: 1 - 2s
- ¹⁾ Input supply from PFC also suitable

General

- Thermal shutdown with auto restart
- ²⁾ Suited for wall-mount, alternatives upon request

- ☉ = natural convection
- ☉ = increased air flow recommended

6U

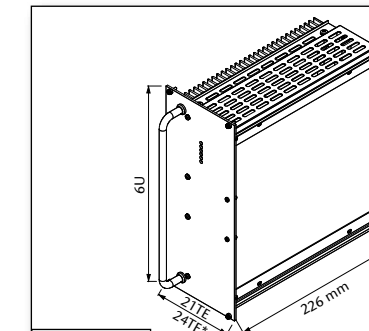

Standard
Eurocassette
(pluggable module for 19" sub-rack) approx. 5.0 kg
*) applicable to 5 V output models

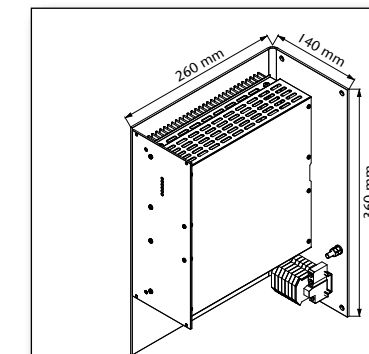

Optional
Wall mount approx. 8.0 kg

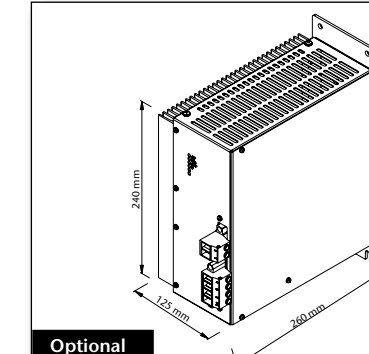

Optional
Chassis mount approx. 5.5 kg
(available for currents up to 60Amps)



DC / DC Converters

▶ 1000 W			▶ 1250 W						Cooling	Output VDC	
Input VDC										Adj.	Range
18-36 VDC	Output Amps	36-75 VDC	45-90 VDC	80-160 VDC	160-320 VDC	320-380 ¹⁾ VDC	320-640 ²⁾ VDC	Output Amps			
C 3720	120	C 3730	C 3740	C 3750	C 3770	C 3780 Z	C 3770 G	150	5	4.5- 5.5	
C 3721	80	C 3731	C 3741	C 3751	C 3771	C 3781 Z	C 3771 G	100	9	8- 10	
C 3722	70	C 3732	C 3742	C 3752	C 3772	C 3782 Z	C 3772 G	85	12	11- 13	
C 3723	56	C 3733	C 3743	C 3753	C 3773	C 3783 Z	C 3773 G	70	15	14- 16	
C 3724	40	C 3734	C 3744	C 3754	C 3774	C 3784 Z	C 3774 G	50	24	23- 26	
C 3725	35	C 3735	C 3745	C 3755	C 3775	C 3785 Z	C 3775 G	42	28	26- 30	
C 3729	19	C 3739	C 3749	C 3759	C 3779	C 3789 Z	C 3779 G	23	48	45- 55	
C 3726	15	C 3736	C 3746	C 3756	C 3776	C 3786 Z	C 3776 G	18	60	58- 68	
C 3727	8	C 3737	C 3747	C 3757	C 3777	C 3787 Z	C 3777 G	10	110	100- 130	
C 3727 J	5	C 3737 J	C 3747 J	C 3757 J	C 3777 J	C 3787 ZJ	C 3777 GJ	6	200	190-200	
C 3728	4	C 3738	C 3748	C 3758	C 3778	C 3788 Z	C 3778 G	5	220	200-250	
C 3728 J	2.5	C 3738 J	C 3748 J	C 3758 J	C 3778 J	C 3788 ZJ	C 3778 GJ	3	400	380-400	

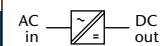

AC / DC Power Supplies

▶ 1250 W									Cooling	Output VDC	
Input VAC, 1-Phase			Input VAC, 3-Phase			Output Amps	Adj.	Range			
115 ±20%	230 ^{+15%} _{-20%}	115 ±20% / 230 ^{+15%} _{-20%}	3x200 ^{+15%} _{-20%}	3x400 ^{+15%} _{-20%}	3x480 ^{+10%} _{-15%}						
C 3760	C 3780	C 3790	C 3760 V	C 3780 V	C 3790 V	150	5	4.5- 5.5			
C 3761	C 3781	C 3791	C 3761 V	C 3781 V	C 3791 V	100	9	8- 10			
C 3762	C 3782	C 3792	C 3762 V	C 3782 V	C 3792 V	85	12	11- 13			
C 3763	C 3783	C 3793	C 3763 V	C 3783 V	C 3793 V	70	15	14- 16			
C 3764	C 3784	C 3794	C 3764 V	C 3784 V	C 3794 V	50	24	23- 26			
C 3765	C 3785	C 3795	C 3765 V	C 3785 V	C 3795 V	42	28	26- 30			
C 3769	C 3789	C 3799	C 3769 V	C 3789 V	C 3799 V	23	48	45- 55			
C 3766	C 3786	C 3796	C 3766 V	C 3786 V	C 3796 V	18	60	58- 68			
C 3767	C 3787	C 3797	C 3767 V	C 3787 V	C 3797 V	10	110	100- 130			
C 3767 J	C 3787 J	C 3797 J	C 3767 VJ	C 3787 VJ	C 3797 VJ	6	200	190-200			
C 3768	C 3788	C 3798	C 3768 V	C 3788 V	C 3798 V	5	220	200-250			
C 3768 J	C 3788 J	C 3798 J	C 3768 VJ	C 3788 VJ	C 3798 VJ	3	400	380-400			

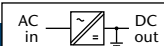

Battery Chargers

▶ 1250 W									Cooling	Output VDC	
Input VAC, 1-Phase			Input VAC, 3-Phase			Output Amps	Nom. Battery Voltage	Range			
115 ±20%	230 ^{+15%} _{-20%}	115 ±20% / 230 ^{+15%} _{-20%}	3x200 ^{+15%} _{-20%}	3x400 ^{+15%} _{-20%}	3x480 ^{+10%} _{-15%}						
B 3761	B 3781	B 3791	B 3761 V	B 3781 V	B 3791 V	75	12	12- 16			
B 3762	B 3782	B 3792	B 3762 V	B 3782 V	B 3792 V	40	24	24- 32			
B 3764	B 3784	B 3794	B 3764 V	B 3784 V	B 3794 V	22	48	48- 64			
B 3766	B 3786	B 3796	B 3766 V	B 3786 V	B 3796 V	18	60	60- 80			
B 3767	B 3787	B 3797	B 3767 V	B 3787 V	B 3797 V	10	110	110- 145			
B 3768	B 3788	B 3798	B 3768 V	B 3788 V	B 3798 V	5	220	220- 290			

Series specific information

Input

- Switch-on time: 1 - 2s
- ¹⁾ Input supply from PFC also suitable

General

- Thermal shutdown with auto restart
- ²⁾ Suited for wall-mount, alternatives upon request

- ☐ = natural convection
- ☉ = increased air flow recommended

6U

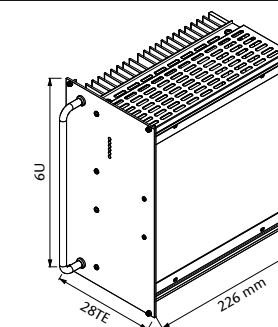

Standard
Eurocassette
(pluggable module for 19" sub-rack) **approx. 6.5 kg**

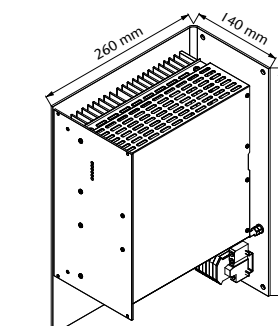

Optional
Wall mount **approx. 9.5 kg**

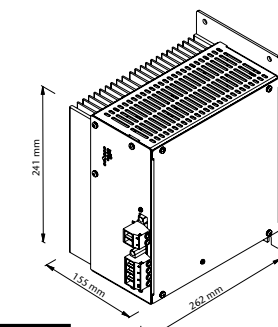

Optional
Chassis mount **approx. 7.5 kg**
(available for currents up to 60Amps)



DC / DC Converters

▶ 900 W			▶ 1200 W			▶ 1600 W						Cooling	Output VDC	
Input VDC													Adj.	Range
10-16 VDC	Output Amps	20-32 VDC	Output Amps	40-64 VDC	50-80 VDC	80-160 VDC	160-320 VDC	320-380 ¹⁾ VDC	320-640 ²⁾ VDC	450-800 ²⁾ VDC	Output Amps			
C 4501	60	C 4521	90	C 4531	C 4541	C 4551	C 4571	C 4581 Z	C 4571 G	C 4571 K	110	9	8- 10	
C 4502	50	C 4522	80	C 4532	C 4542	C 4552	C 4572	C 4582 Z	C 4572 G	C 4572 K	96	12	11- 13	
C 4503	42	C 4523	65	C 4533	C 4543	C 4553	C 4573	C 4583 Z	C 4573 G	C 4573 K	80	15	14- 16	
C 4504	32	C 4524	45	C 4534	C 4544	C 4554	C 4574	C 4584 Z	C 4574 G	C 4574 K	56	24	23- 26	
C 4505	28	C 4525	40	C 4535	C 4545	C 4555	C 4575	C 4585 Z	C 4575 G	C 4575 K	50	28	26- 30	
C 4509	16	C 4529	22	C 4539	C 4549	C 4559	C 4579	C 4589 Z	C 4579 G	C 4579 K	30	48	45- 55	
C 4506	14	C 4526	18	C 4536	C 4546	C 4556	C 4576	C 4586 Z	C 4576 G	C 4576 K	24	60	58- 68	
C 4507	7.2	C 4527	10	C 4537	C 4547	C 4557	C 4577	C 4587 Z	C 4577 G	C 4577 K	13	110	100- 130	
C 4507 J	4.4	C 4527 J	6	C 4537 J	C 4547 J	C 4557 J	C 4577 J	C 4587 ZJ	C 4577 GJ	C 4577 KJ	8	200	190- 200	
C 4508	3.6	C 4528	5	C 4538	C 4548	C 4558	C 4578	C 4588 Z	C 4578 G	C 4578 K	6.5	220	200- 250	
C 4508 J	2.2	C 4528 J	3	C 4538 J	C 4548 J	C 4558 J	C 4578 J	C 4588 ZJ	C 4578 GJ	C 4578 KJ	4	400	380- 400	

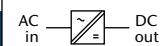

AC / DC Power Supplies

▶ 1600 W										Cooling	Output VDC	
Input VAC, 1-Phase					Input VAC, 3-Phase			Output Amps	Adj.		Range	
115 ±20%	230 ^{+15%} _{-20%}	115 ±20% / 230 ^{+15%} _{-20%}	3x200 ^{+15%} _{-20%}	3x400 ^{+15%} _{-20%}	3x480 ^{+10%} _{-15%}							
C 4561	C 4581	C 4591	C 4561 V	C 4581 V	C 4591 V	110	9	8- 10				
C 4562	C 4582	C 4592	C 4562 V	C 4582 V	C 4592 V	96	12	11- 13				
C 4563	C 4583	C 4593	C 4563 V	C 4583 V	C 4593 V	80	15	14- 16				
C 4564	C 4584	C 4594	C 4564 V	C 4584 V	C 4594 V	56	24	23- 26				
C 4565	C 4585	C 4595	C 4565 V	C 4585 V	C 4595 V	50	28	26- 30				
C 4569	C 4589	C 4599	C 4569 V	C 4589 V	C 4599 V	30	48	45- 55				
C 4566	C 4586	C 4596	C 4566 V	C 4586 V	C 4596 V	24	60	58- 68				
C 4567	C 4587	C 4597	C 4567 V	C 4587 V	C 4597 V	13	110	100- 130				
C 4567 J	C 4587 J	C 4597 J	C 4567 VJ	C 4587 VJ	C 4597 VJ	8	200	190- 200				
C 4568	C 4588	C 4598	C 4568 V	C 4588 V	C 4598 V	6.5	220	200- 250				
C 4568 J	C 4588 J	C 4598 J	C 4568 VJ	C 4588 VJ	C 4598 VJ	4	400	380- 400				

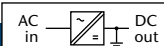

Battery Chargers

▶ 1600 W										Cooling	Output VDC	
Input VAC, 1-Phase					Input VAC, 3-Phase			Output Amps	Nom. Battery Voltage		Range	
115 ±20%	230 ^{+15%} _{-20%}	115 ±20% / 230 ^{+15%} _{-20%}	3x200 ^{+15%} _{-20%}	3x400 ^{+15%} _{-20%}	3x480 ^{+10%} _{-15%}							
B 4561	B 4581	B 4591	B 4561 V	B 4581 V	B 4591 V	80	12	12- 16				
B 4562	B 4582	B 4592	B 4562 V	B 4582 V	B 4592 V	46	24	24- 32				
B 4564	B 4584	B 4594	B 4564 V	B 4584 V	B 4594 V	25	48	48- 64				
B 4566	B 4586	B 4596	B 4566 V	B 4586 V	B 4596 V	20	60	60- 80				
B 4567	B 4587	B 4597	B 4567 V	B 4587 V	B 4597 V	12	110	110- 145				
B 4568	B 4588	B 4598	B 4568 V	B 4588 V	B 4598 V	6	220	220- 290				

Series specific information

Input

- Switch-on time: 1 - 2s
- ¹⁾ Input supply from PFC also suitable

General

- Thermal shutdown with auto restart
- ²⁾ Suited for wall-mount, alternatives upon request
- ☉ = increased air flow recommended

6U

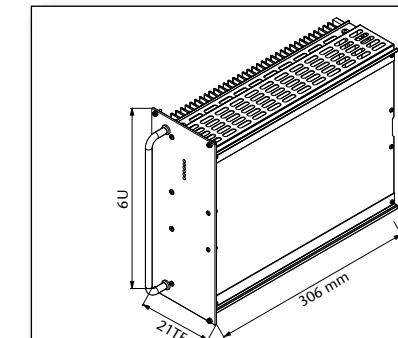

Standard

Eurocassette (pluggable module for 19" sub-rack) approx. 6.5 kg

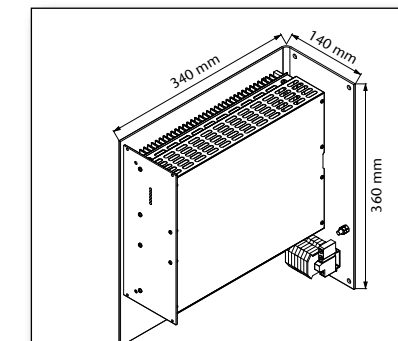

Optional

Wall mount approx. 10.0 kg

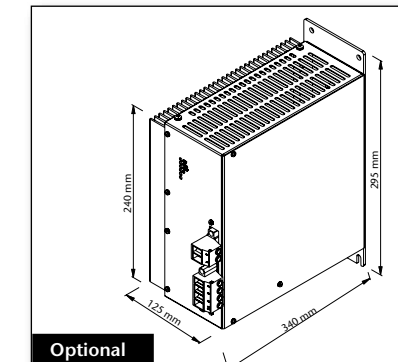

Optional

Chassis mount (available for currents up to 60Amps) approx. 7.5 kg

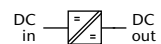

DC / DC Converters

▶ 1400 W			▶ 1700 W							Cooling	Output VDC	
Input VDC											Adj.	Range
18-32 VDC	Output Amps	36-75 VDC	45-90 VDC	80-160 VDC	160-320 VDC	320-380 ¹⁾ VDC	320-640 ²⁾ VDC	450-800 ²⁾ VDC	Output Amps			
C 3620	180 ²⁾	C 3630	C 3640	C 3650	C 3670	C 3680 Z	C 3670 G	C 3670 K	200 ²⁾	5	4.5- 5.5	
C 3621	120	C 3631	C 3641	C 3651	C 3671	C 3681 Z	C 3671 G	C 3671 K	130	9	8- 10	
C 3622	100	C 3632	C 3642	C 3652	C 3672	C 3682 Z	C 3672 G	C 3672 K	115	12	11- 13	
C 3623	80	C 3633	C 3643	C 3653	C 3673	C 3683 Z	C 3673 G	C 3673 K	90	15	14- 16	
C 3624	55	C 3634	C 3644	C 3654	C 3674	C 3684 Z	C 3674 G	C 3674 K	65	24	23- 26	
C 3625	48	C 3635	C 3645	C 3655	C 3675	C 3685 Z	C 3675 G	C 3675 K	55	28	26- 30	
C 3629	26	C 3639	C 3649	C 3659	C 3679	C 3689 Z	C 3679 G	C 3679 K	30	48	45- 55	
C 3626	21	C 3636	C 3646	C 3656	C 3676	C 3686 Z	C 3676 G	C 3676 K	25	60	58- 68	
C 3627	11	C 3637	C 3647	C 3657	C 3677	C 3687 Z	C 3677 G	C 3677 K	14	110	100- 130	
C 3627 J	7	C 3637 J	C 3647 J	C 3657 J	C 3677 J	C 3687 ZJ	C 3677 GJ	C 3677 KJ	8.5	200	190- 200	
C 3628	5.5	C 3638	C 3648	C 3658	C 3678	C 3688 Z	C 3678 G	C 3678 K	7	220	200- 250	
C 3628 J	3.5	C 3638 J	C 3648 J	C 3658 J	C 3678 J	C 3688 ZJ	C 3678 GJ	C 3678 KJ	4.3	400	380- 400	

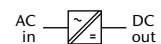

AC / DC Power Supplies

▶ 1700 W										Cooling	Output VDC	
Input VAC, 1-Phase			Input VAC, 3-Phase			Output Amps	Adj.	Range				
115 ±20%	230 ^{+15%} _{-20%}	115 ±20% / 230 ^{+15%} _{-20%}	3x200 ^{+15%} _{-20%}	3x400 ^{+15%} _{-20%}	3x480 ^{+10%} _{-15%}							
C 3660	C 3680	C 3690	C 3660 V	C 3680 V	C 3690 V	200 ²⁾	5	4.5- 5.5				
C 3661	C 3681	C 3691	C 3661 V	C 3681 V	C 3691 V	130	9	8- 10				
C 3662	C 3682	C 3692	C 3662 V	C 3682 V	C 3692 V	115	12	11- 13				
C 3663	C 3683	C 3693	C 3663 V	C 3683 V	C 3693 V	90	15	14- 16				
C 3664	C 3684	C 3694	C 3664 V	C 3684 V	C 3694 V	65	24	23- 26				
C 3665	C 3685	C 3695	C 3665 V	C 3685 V	C 3695 V	55	28	26- 30				
C 3669	C 3689	C 3699	C 3669 V	C 3689 V	C 3699 V	30	48	45- 55				
C 3666	C 3686	C 3696	C 3666 V	C 3686 V	C 3696 V	25	60	58- 68				
C 3667	C 3687	C 3697	C 3667 V	C 3687 V	C 3697 V	14	110	100- 130				
C 3667 J	C 3687 J	C 3697 J	C 3667 VJ	C 3687 VJ	C 3697 VJ	8.5	200	190- 200				
C 3668	C 3688	C 3698	C 3668 V	C 3688 V	C 3698 V	7	220	200- 250				
C 3668 J	C 3688 J	C 3698 J	C 3668 VJ	C 3688 VJ	C 3698 VJ	4.3	400	380- 400				

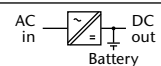

Battery Chargers

▶ 1700 W										Cooling	Output VDC	
Input VAC, 1-Phase			Input VAC, 3-Phase			Output Amps	Nom. Battery Voltage	Range				
115 ±20%	230 ^{+15%} _{-20%}	115 ±20% / 230 ^{+15%} _{-20%}	3x200 ^{+15%} _{-20%}	3x400 ^{+15%} _{-20%}	3x480 ^{+10%} _{-15%}							
B 3661	B 3681	B 3691	B 3661 V	B 3681 V	B 3691 V	100	12	12- 16				
B 3662	B 3682	B 3692	B 3662 V	B 3682 V	B 3692 V	55	24	24- 32				
B 3664	B 3684	B 3694	B 3664 V	B 3684 V	B 3694 V	30	48	48- 64				
B 3666	B 3686	B 3696	B 3666 V	B 3686 V	B 3696 V	24	60	60- 80				
B 3667	B 3687	B 3697	B 3667 V	B 3687 V	B 3697 V	14	110	110- 145				
B 3668	B 3688	B 3698	B 3668 V	B 3688 V	B 3698 V	7	220	220- 290				

Series specific information

Input

- Switch-on time: 1 - 2s
- ¹⁾ Input supply from PFC also suitable

General

- Thermal shutdown with auto restart
- ²⁾ Suited for wall-mount, alternatives upon request

- = natural convection
- = increased air flow recommended

6U

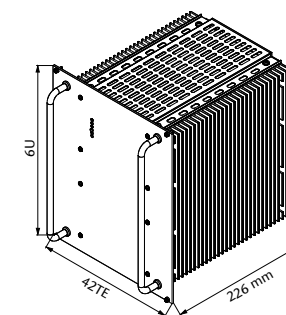

Standard
Eurocassette (pluggable module for 19" sub-rack) approx. 10.0 kg

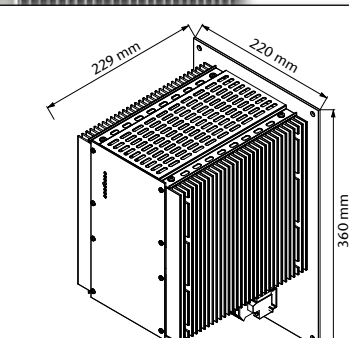

Optional
Wall mount approx. 12.5 kg

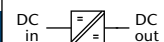

DC / DC Converters

▶ 1200 W		▶ 1700 W		▶ 2500 W		▶ 2500 W						Cooling	Output VDC	
Input VDC										Adj.	Range			
10–16 VDC	Output Amps	20–32 VDC	Output Amps	40–64 VDC	50–80 VDC	Output Amps	80–160 VDC	160–320 VDC	320–380 ¹⁾ VDC				320–640 ²⁾ VDC	450–800 ²⁾ VDC
C 4700	100	C 4720	160 ²⁾	C 4730	C 4740	180 ²⁾	C 4750	C 4770	C 4780 Z	C 4770 G	C 4770 K	180 ²⁾	5	4.5– 5.5
C 4701	80	C 4721	110	C 4731	C 4741	140	C 4751	C 4771	C 4781 Z	C 4771 G	C 4771 K	150	9	8– 10
C 4702	68	C 4722	95	C 4732	C 4742	120	C 4752	C 4772	C 4782 Z	C 4772 G	C 4772 K	130	12	11– 13
C 4703	58	C 4723	80	C 4733	C 4743	100	C 4753	C 4773	C 4783 Z	C 4773 G	C 4773 K	110	15	14– 16
C 4704	46	C 4724	60	C 4734	C 4744	75	C 4754	C 4774	C 4784 Z	C 4774 G	C 4774 K	80	24	23– 26
C 4705	40	C 4725	50	C 4735	C 4745	65	C 4755	C 4775	C 4785 Z	C 4775 G	C 4775 K	70	28	26– 30
C 4709	22	C 4729	30	C 4739	C 4749	38	C 4759	C 4779	C 4789 Z	C 4779 G	C 4779 K	40	48	45– 55
C 4706	18	C 4726	25	C 4736	C 4746	31	C 4756	C 4776	C 4786 Z	C 4776 G	C 4776 K	33	60	58– 68
C 4707	10	C 4727	13	C 4737	C 4747	18	C 4757	C 4777	C 4787 Z	C 4777 G	C 4777 K	20	110	100– 130
C 4707 J	6	C 4727 J	7	C 4737 J	C 4747 J	10	C 4757 J	C 4777 J	C 4787 ZJ	C 4777 GJ	C 4777 KJ	10	200	190– 200
C 4708	5	C 4728	7	C 4738	C 4748	10	C 4758	C 4778	C 4788 Z	C 4778 G	C 4778 K	10	220	200– 250
C 4708 J	3	C 4728 J	3.5	C 4738 J	C 4748 J	5	C 4758 J	C 4778 J	C 4788 ZJ	C 4778 GJ	C 4778 KJ	5	400	380– 400

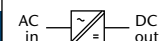

AC / DC Power Supplies

▶ 1700 W		▶ 2500 W						Output Amps	Cooling	Output VDC		
Input VAC, 1-Phase						Input VAC, 3-Phase				Adj.	Range	
100–240 ±10% with PFC	Output Amps	115 ±20%	230 ^{+15%} _{-20%}	115 ±20% / 230 ^{+15%} _{-20%}	3x200 ^{+15%} _{-20%}	3x400 ^{+15%} _{-20%}	3x480 ^{+10%} _{-15%}					
CP 4790	180 ²⁾	C 4760	C 4780	C 4790	C 4760 V	C 4780 V	C 4790 V	180 ²⁾	5	4.5– 5.5		
CP 4791	150	C 4761	C 4781	C 4791	C 4761 V	C 4781 V	C 4791 V	150	9	8– 10		
CP 4792	120	C 4762	C 4782	C 4792	C 4762 V	C 4782 V	C 4792 V	130	12	11– 13		
CP 4793	100	C 4763	C 4783	C 4793	C 4763 V	C 4783 V	C 4793 V	110	15	14– 16		
CP 4794	70	C 4764	C 4784	C 4794	C 4764 V	C 4784 V	C 4794 V	80	24	23– 26		
CP 4795	60	C 4765	C 4785	C 4795	C 4765 V	C 4785 V	C 4795 V	70	28	26– 30		
CP 4799	35	C 4769	C 4789	C 4799	C 4769 V	C 4789 V	C 4799 V	40	48	45– 55		
CP 4796	25	C 4766	C 4786	C 4796	C 4766 V	C 4786 V	C 4796 V	33	60	58– 68		
CP 4797	14	C 4767	C 4787	C 4797	C 4767 V	C 4787 V	C 4797 V	20	110	100– 130		
CP 4797 J	7	C 4767 J	C 4787 J	C 4797 J	C 4767 VJ	C 4787 VJ	C 4797 VJ	10	200	190– 200		
CP 4798	7	C 4768	C 4788	C 4798	C 4768 V	C 4788 V	C 4798 V	10	220	200– 250		
CP 4798 J	3.5	C 4768 J	C 4788 J	C 4798 J	C 4768 VJ	C 4788 VJ	C 4798 VJ	5	400	380– 400		

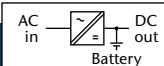

Battery Chargers

▶ 1700 W		▶ 2500 W						Output Amps	Cooling	Output VDC		
Input VAC, 1-Phase						Input VAC, 3-Phase				Nom. Battery Voltage	Range	
100–240 ±10% with PFC	Output Amps	115 ±20%	230 ^{+15%} _{-20%}	115 ±20% / 230 ^{+15%} _{-20%}	3x200 ^{+15%} _{-20%}	3x400 ^{+15%} _{-20%}	3x480 ^{+10%} _{-15%}					
BP 4791	100	B 4761	B 4781	B 4791	B 4761 V	B 4781 V	B 4791 V	110	12	12– 16		
BP 4792	56	B 4762	B 4782	B 4792	B 4762 V	B 4782 V	B 4792 V	70	24	24– 32		
BP 4794	28	B 4764	B 4784	B 4794	B 4764 V	B 4784 V	B 4794 V	35	48	48– 64		
BP 4796	22	B 4766	B 4786	B 4796	B 4766 V	B 4786 V	B 4796 V	30	60	60– 80		
BP 4797	12	B 4767	B 4787	B 4797	B 4767 V	B 4787 V	B 4797 V	18	110	110– 145		
BP 4798	6	B 4768	B 4788	B 4798	B 4768 V	B 4788 V	B 4798 V	9	220	220– 290		

Series specific information

Input

- Switch-on time: 1 - 2s
- Power factor correction for CP/ BP series, acc. to EN 61000-3-2, class D
- ¹⁾ Input supply from external PFC also suitable

General

- Thermal shutdown with auto restart
- ²⁾ Suited for wall-mount, alternatives upon request

☉ = increased air flow recommended

6U

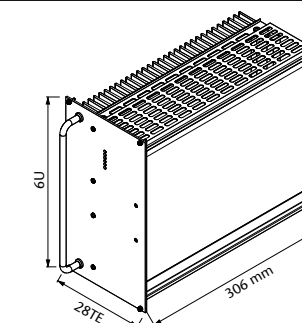

Standard

Eurocassette (pluggable module for 19" sub-rack) approx. 9.0 kg

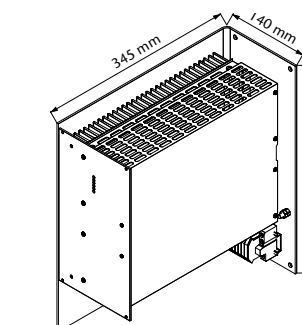

Optional

Wall mount approx. 13.0 kg

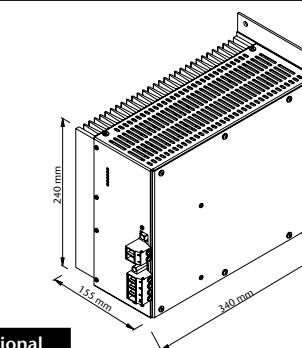

Optional

Chassis mount (available for currents up to 60Amps) approx. 10.0 kg



DC / DC Converters

▶ 2000 W		▶ 2500 W										Cooling	Output VDC	
Input VDC													Adj.	Range
18–32 VDC	Output Amps	36–75 VDC	45–90 VDC	80–160 VDC	160–320 VDC	320–380 ¹⁾ VDC	320–640 ²⁾ VDC	450–800 ²⁾ VDC	Output Amps					
C 3822	120	C 3832	C 3842	C 3852	C 3872	C 3882 Z	C 3872 G	C 3872 K	160 ²⁾		12	11– 13		
C 3823	100	C 3833	C 3843	C 3853	C 3873	C 3883 Z	C 3873 G	C 3873 K	130		15	14– 16		
C 3824	75	C 3834	C 3844	C 3854	C 3874	C 3884 Z	C 3874 G	C 3874 K	100		24	23– 26		
C 3825	65	C 3835	C 3845	C 3855	C 3875	C 3885 Z	C 3875 G	C 3875 K	85		28	26– 30		
C 3829	38	C 3839	C 3849	C 3859	C 3879	C 3889 Z	C 3879 G	C 3879 K	45		48	45– 55		
C 3826	30	C 3836	C 3846	C 3856	C 3876	C 3886 Z	C 3876 G	C 3876 K	36		60	58– 68		
C 3827	15	C 3837	C 3847	C 3857	C 3877	C 3887 Z	C 3877 G	C 3877 K	20		110	100– 130		
C 3827 J	10	C 3837 J	C 3847 J	C 3857 J	C 3877 J	C 3887 ZJ	C 3877 GJ	C 3877 KJ	12		200	190– 200		
C 3828	8	C 3838	C 3848	C 3858	C 3878	C 3888 Z	C 3878 G	C 3878 K	10		220	200– 250		
C 3828 J	5	C 3838 J	C 3848 J	C 3858 J	C 3878 J	C 3888 ZJ	C 3878 GJ	C 3878 KJ	6		400	380– 400		

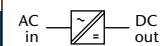

AC / DC Power Supplies

▶ 2500 W										Cooling	Output VDC	
Input VAC, 1-Phase			Input VAC, 3-Phase			Output Amps	Adj.	Range				
115 ±20%	230 ^{+15%} _{-20%}	115 ±20% / 230 ^{+15%} _{-20%}	3x200 ^{+15%} _{-20%}	3x400 ^{+15%} _{-20%}	3x480 ^{+10%} _{-15%}							
C 3862	C 3882	C 3892	C 3862 V	C 3882 V	C 3892 V	160 ²⁾		12	11– 13			
C 3863	C 3883	C 3893	C 3863 V	C 3883 V	C 3893 V	130		15	14– 16			
C 3864	C 3884	C 3894	C 3864 V	C 3884 V	C 3894 V	100		24	23– 26			
C 3865	C 3885	C 3895	C 3865 V	C 3885 V	C 3895 V	85		28	26– 30			
C 3869	C 3889	C 3899	C 3869 V	C 3889 V	C 3899 V	45		48	45– 55			
C 3866	C 3886	C 3896	C 3866 V	C 3886 V	C 3896 V	36		60	58– 68			
C 3867	C 3887	C 3897	C 3867 V	C 3887 V	C 3897 V	20		110	100– 130			
C 3867 J	C 3887 J	C 3897 J	C 3867 VJ	C 3887 VJ	C 3897 VJ	12		200	190– 200			
C 3868	C 3888	C 3898	C 3868 V	C 3888 V	C 3898 V	10		220	200– 250			
C 3868 J	C 3888 J	C 3898 J	C 3868 VJ	C 3888 VJ	C 3898 VJ	6		400	380– 400			

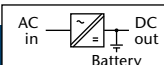

Battery Chargers

▶ 2500 W										Cooling	Output VDC	
Input VAC, 1-Phase			Input VAC, 3-Phase			Output Amps	Nom. Battery Voltage	Range				
115 ±20%	230 ^{+15%} _{-20%}	115 ±20% / 230 ^{+15%} _{-20%}	3x200 ^{+15%} _{-20%}	3x400 ^{+15%} _{-20%}	3x480 ^{+10%} _{-15%}							
B 3861	B 3881	B 3891	B 3861 V	B 3881 V	B 3891 V	150	12	12– 16				
B 3862	B 3882	B 3892	B 3862 V	B 3882 V	B 3892 V	80	24	24– 32				
B 3864	B 3884	B 3894	B 3864 V	B 3884 V	B 3894 V	45	48	48– 64				
B 3866	B 3886	B 3896	B 3866 V	B 3886 V	B 3896 V	35	60	60– 80				
B 3867	B 3887	B 3897	B 3867 V	B 3887 V	B 3897 V	20	110	110– 145				
B 3868	B 3888	B 3898	B 3868 V	B 3888 V	B 3898 V	10	220	220– 290				

Series specific information

Input

- Switch-on time: 1 - 2s
- ¹⁾ Input supply from PFC also suitable

General

- Thermal shutdown with auto restart
- ²⁾ Suited for wall-mount, alternatives upon request

- = natural convection
- = increased air flow recommended

6U

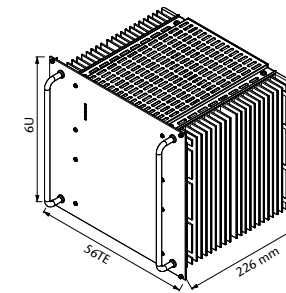

Standard Eurocassette (pluggable module for 19" sub-rack) approx. 13.0 kg

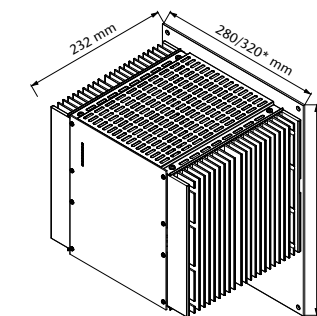

Optional Wall mount approx. 16 kg/ *) 19 kg
*) applicable to models >= 150 A output current



DC / DC Converters

→ ZVS topology

▶ 2.5 kW		▶ 3.5 kW		▶ 5 kW		▶ 5 kW						Cooling	Output VDC		
Input VDC													Adj.	Range	
10-16 ²⁾ VDC	Output Amps	20-32 ²⁾ VDC	Output Amps	40-64 VDC	50-80 VDC	Output Amps	80-160 VDC	160-320 VDC	320-380 ¹⁾ VDC	320-640 ²⁾ VDC	450-800 ²⁾ VDC	Output Amps			
C 4802	136	C 4822	190	C 4832	C 4842	240 ²⁾	C 4852	C 4872	C 4882 Z	C 4872 G	C 4872 K	260 ²⁾	12	11 - 13	
C 4803	116	C 4823	160	C 4833	C 4843	200 ²⁾	C 4853	C 4873	C 4883 Z	C 4873 G	C 4873 K	220 ²⁾	15	14 - 16	
C 4804	92	C 4824	120	C 4834	C 4844	150	C 4854	C 4874	C 4884 Z	C 4874 G	C 4874 K	160 ²⁾	24	23 - 26	
C 4805	80	C 4825	100	C 4835	C 4845	130	C 4855	C 4875	C 4885 Z	C 4875 G	C 4875 K	140	28	26 - 30	
C 4809	44	C 4829	60	C 4839	C 4849	76	C 4859	C 4879	C 4889 Z	C 4879 G	C 4879 K	80	48	45 - 55	
C 4806	36	C 4826	50	C 4836	C 4846	62	C 4856	C 4876	C 4886 Z	C 4876 G	C 4876 K	66	60	58 - 68	
C 4807	20	C 4827	26	C 4837	C 4847	36	C 4857	C 4877	C 4887 Z	C 4877 G	C 4877 K	40	110	100 - 130	
C 4807 J	12	C 4827 J	14	C 4837 J	C 4847 J	20	C 4857 J	C 4877 J	C 4887 ZJ	C 4877 GJ	C 4877 KJ	20	200	190 - 200	
C 4808	10	C 4828	14	C 4838	C 4848	20	C 4858	C 4878	C 4888 Z	C 4878 G	C 4878 K	20	220	200 - 250	
C 4808 J	6	C 4828 J	7	C 4838 J	C 4848 J	10	C 4858 J	C 4878 J	C 4888 ZJ	C 4878 GJ	C 4878 KJ	10	400	380 - 400	

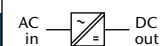

AC / DC Power Supplies

→ ZVS topology

▶ 4 kW		▶ 5 kW						Cooling	Output VDC	
Input VAC, 1-Phase			Input VAC, 3-Phase			Output Amps	Adj.		Range	
115 ²⁾ ±20%	Output Amps	230 ^{+15%} -20%	3x200 ^{+15%} -20%	3x400 ^{+15%} -20%	3x480 ^{+10%} -15%					
C 4862	260	C 4882	C 4862 V	C 4882 V	C 4892 V	260 ²⁾	12	11 - 13		
C 4863	220	C 4883	C 4863 V	C 4883 V	C 4893 V	220 ²⁾	15	14 - 16		
C 4864	150	C 4884	C 4864 V	C 4884 V	C 4894 V	160 ²⁾	24	23 - 26		
C 4865	130	C 4885	C 4865 V	C 4885 V	C 4895 V	140	28	26 - 30		
C 4869	72	C 4889	C 4869 V	C 4889 V	C 4899 V	80	48	45 - 55		
C 4866	60	C 4886	C 4866 V	C 4886 V	C 4896 V	66	60	58 - 68		
C 4867	30	C 4887	C 4867 V	C 4887 V	C 4897 V	40	110	100 - 130		
C 4867 J	16	C 4887 J	C 4867 VJ	C 4887 VJ	C 4897 VJ	20	200	190 - 200		
C 4868	16	C 4888	C 4868 V	C 4888 V	C 4898 V	20	220	200 - 250		
C 4868 J	8	C 4888 J	C 4868 VJ	C 4888 VJ	C 4898 VJ	10	400	380 - 400		



Battery Chargers

→ ZVS topology

▶ 4 kW		▶ 5 kW						Cooling	Output VDC	
Input VAC, 1-Phase			Input VAC, 3-Phase			Output Amps	Nom. Battery Voltage		Range	
115 ²⁾ ±20%	Output Amps	230 ^{+15%} -20%	3x200 ^{+15%} -20%	3x400 ^{+15%} -20%	3x480 ^{+10%} -15%					
B 4861	220	B 4881	B 4861 V	B 4881 V	B 4891 V	220 ²⁾	12	12 - 16		
B 4862	122	B 4882	B 4862 V	B 4882 V	B 4892 V	140	24	24 - 32		
B 4864	62	B 4884	B 4864 V	B 4884 V	B 4894 V	70	48	48 - 64		
B 4866	50	B 4886	B 4866 V	B 4886 V	B 4896 V	60	60	60 - 80		
B 4867	28	B 4887	B 4867 V	B 4887 V	B 4897 V	34	110	110 - 145		
B 4868	14	B 4888	B 4868 V	B 4888 V	B 4898 V	18	220	220 - 290		

Series specific information

Input

- No-load input power: 15W typical
- Switch-on time: 1 - 2s
- Inrush current: 230V AC and 3-phase input: limited by thermistor
- Hold-up time for AC input: 5ms typical @ nominal input voltage

Output

- Response time to ±1%: 5 - 10ms
- Turn-on rise time: Soft-start, 100-300ms typical
- OVP without restart for ZVS

General

- Thermal shutdown with auto restart
- Option "rco" for ZVS-modules available (see p.118)
- ¹⁾ Input supply from PFC also suitable
- ²⁾ Suited for wall-mount, alternatives upon request
- ☉ = increased air flow recommended

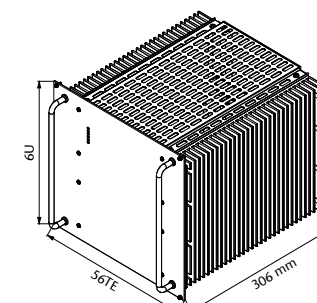

Standard Eurocassette (pluggable module for 19" sub-rack)

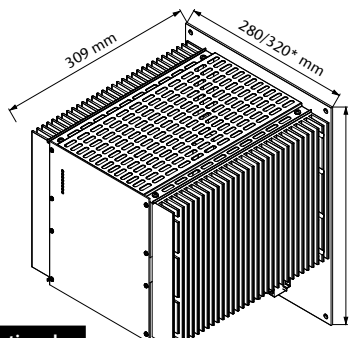

Optional Wall mount approx. 19 kg/ *) 22 kg *) applicable to models >= 150 A input or output current

6U





DC / DC Converters series C 5600

▶ 2.5 kW			▶ 3.5 kW			▶ 5 kW			Cooling	Output VDC	
Input VDC										Adj.	Range
10-16 VDC	Output Amps	20-32 VDC	Output Amps	40-64 VDC	50-80 VDC	Output Amps					
C 5600	200	C 5620	320	C 5630	C 5640	360	★	5	4.5 - 5.5		
C 5601	160	C 5621	220	C 5631	C 5641	280	★	9	8 - 10		
C 5602	136	C 5622	190	C 5632	C 5642	240	★	12	11 - 13		
C 5603	116	C 5623	160	C 5633	C 5643	200	★	15	14 - 16		
C 5604	92	C 5624	120	C 5634	C 5644	150	★	24	23 - 26		
C 5605	80	C 5625	100	C 5635	C 5645	130	★	28	26 - 30		
C 5609	44	C 5629	60	C 5639	C 5649	76	★	48	45 - 55		
C 5606	36	C 5626	50	C 5636	C 5646	62	★	60	58 - 68		
C 5607	20	C 5627	26	C 5637	C 5647	36	★	110	100 - 130		
C 5607 J	12	C 5627 J	14	C 5637 J	C 5647 J	20	★	200	190 - 200		
C 5608	10	C 5628	14	C 5638	C 5648	20	★	220	200 - 250		
C 5608 J	6	C 5628 J	7	C 5638 J	C 5648 J	10	★	400	380 - 400		

Series C 5600 and C 4800 are electrically identical up to 80 VDC input.

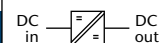

DC / DC Converters series C 5700

▶ 3.6 kW			▶ 5.1 kW			▶ 7.5 kW			Cooling	Output VDC	
Input VDC										Adj.	Range
10-16 VDC	Output Amps	20-32 VDC	Output Amps	40-64 VDC	50-80 VDC	Output Amps					
C 5700	300	C 5720	450	C 5730	C 5740	500	★	5	4.5 - 5.5		
C 5701	240	C 5721	330	C 5731	C 5741	400	★	9	8 - 10		
C 5702	204	C 5722	285	C 5732	C 5742	360	★	12	11 - 13		
C 5703	174	C 5723	240	C 5733	C 5743	300	★	15	14 - 16		
C 5704	138	C 5724	180	C 5734	C 5744	225	★	24	23 - 26		
C 5705	120	C 5725	150	C 5735	C 5745	195	★	28	26 - 30		
C 5709	66	C 5729	90	C 5739	C 5749	114	★	48	45 - 55		
C 5706	54	C 5726	75	C 5736	C 5746	93	★	60	58 - 68		
C 5707	30	C 5727	39	C 5737	C 5747	54	★	110	100 - 130		
C 5707 J	18	C 5727 J	21	C 5737 J	C 5747 J	30	★	200	190 - 200		
C 5708	15	C 5728	21	C 5738	C 5748	30	★	220	200 - 250		
C 5708 J	9	C 5728 J	10.5	C 5738 J	C 5748 J	15	★	400	380 - 400		

Series specific information

Input

- No-load input power: 15 - 20W
- Switch-on time: 1 - 2s

Output

- Manual adjustment of output voltage only via external potentiometer

General

- Thermal shutdown with auto restart
- MTBF: approx. 70,000h @ 40°C acc. to MIL - HDBK - 217E (notice 1)
- ★ = incl. temperature controlled fans

6U

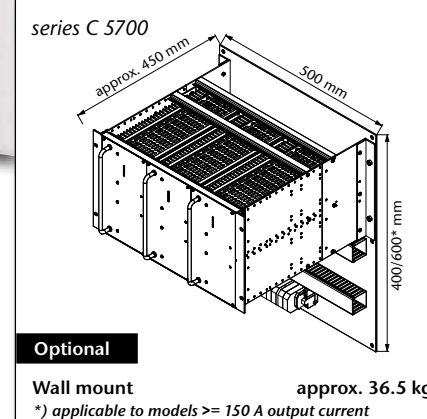
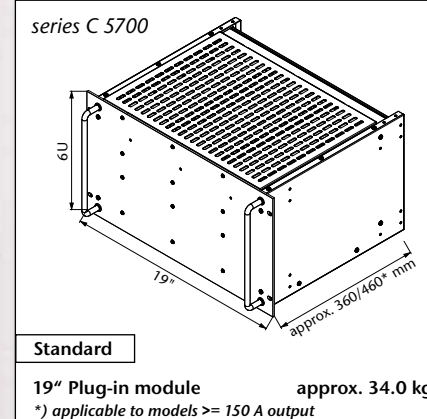
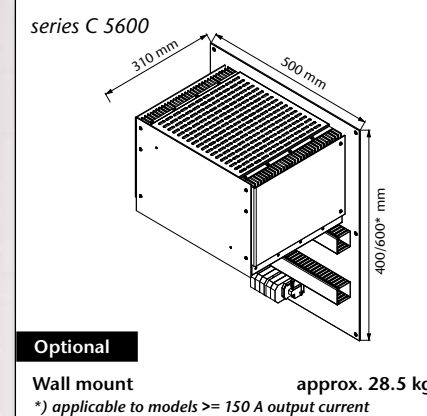
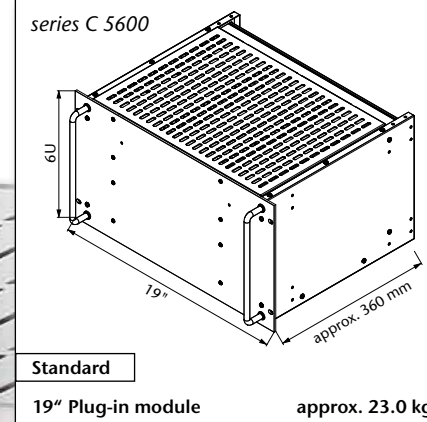

Step-up converters

The step-up converters are very similar to the DC/DC converters of series "C", except that the step-up converters sense the voltage across the load which is the total of the battery voltage and the voltage added by the step-up converter. The step-up converter can not reduce the voltage being applied to its input. Therefore, the load should be specified for the maximum battery voltage.

For output voltage stabilization

The output voltage of an e.g. battery charger with parallel connected battery varies substantially with the charging condition of the battery. For many applications, however, the load circuit requires a better stabilized voltage. Frequently used methods for reducing the voltage variation are e.g. "voltage dropping diodes". A more economical solution is given by switch mode step-up converters. These are DC/DC converters supplied from the battery with the output connected in series to the battery. Due to the circuit configuration, the output of a step-up converter is not isolated from the input supply (battery).



Operation diagram

- During normal operation no voltage needs to be added and the converter runs with a minimum of power losses. The voltage at the load is slightly reduced as the current flows through the bypass diode. The bypass diode also allows for replacement of the step-up converter and should therefore be installed externally.
- During battery discharge the converter adds the voltage that is needed to maintain the required output voltage level.
- The maximum voltage to be added is normally less than 20 % of the total voltage. Therefore, the step-up converter needs to be designed for 20 % of the through-power, only.

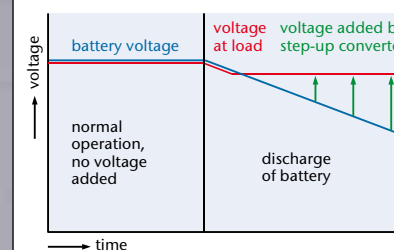

Example:
 ■ Input: 40 – 56 VDC (battery)
 ■ Output: 0 – 10 VDC (step-up voltage)
 output voltage regulated to 50 V during discharge of battery

Circuit diagrams

Step-up converter with common positive line

The following circuit diagram shows a step-up converter which can be grounded on the positive side. The voltage will be added at the negative side and the positive line is common for input and output.

Step-up converter with common negative line

The following circuit diagram shows a step-up converter which can be grounded on the negative side. The voltage will be added at the positive side and the negative line is common for input and output.

Parallel operation of step-up converters

For more power or redundancy step-up converters may be connected in parallel with active current sharing, individually protected by fuses at the input and decoupling diodes or fuses at the output. Such systems have already been realized for 2,000 Amps.

Individual load supply

For applications that require individually stabilized voltages across the loads, the step-converters will be connected as shown in the following diagram and may be of different power ratings.

Create your step-up converter

- Each DC/DC converter can be modified to be a step-up converter:
- calculate the output power of the step-up converter: max. voltage to be added x max. load current
 - choose the suitable "C" series
 - re-name the model as "E" ...

▶ 1000 W		▶ 1250 W								
		Input VDC						Output VDC		
18–36 VDC	Output Amps	36–75 VDC	45–90 VDC	80–160 VDC	160–320 VDC	320–380 ¹⁾ VDC	320–640 ³⁾ VDC	Output Amps	Adj.	Range
C 3720	120 ²⁾	C 3730	C 3740	C 3750	C 3770	C 3780 Z	C 3770 G	150 ²⁾	5	4.5– 5.5
C 3721	80	C 3731	C 3741	C 3751	C 3771	C 3781 Z	C 3771 G	100	9	8– 10
C 3726	15	C 3736	C 3746	C 3756	C 3776	C 3786 Z	C 3776 G	18	60	58– 68
C 3727	8	C 3737	C 3747	C 3757	C 3777	C 3787 Z	C 3777 G	10	110	100– 130
C 3727 J	5	C 3737 J	C 3747 J	C 3757 J	C 3777 J	C 3787 ZJ	C 3777 GJ	6	200	190–200
C 3728	4	C 3738	C 3748	C 3758	C 3778	C 3788 Z	C 3778 G	5	220	200–250
C 3728 J	2.5	C 3738 J	C 3748 J	C 3758 J	C 3778 J	C 3788 ZJ	C 3778 GJ	3	400	380–400

Example:

Step-up Converters

▶ 1000 W		▶ 1250 W								
		Input VDC (battery voltage)						Output VDC		
18–36 VDC	Output Amps	36–75 VDC	45–90 VDC	80–160 VDC	160–320 VDC	320–380 ¹⁾ VDC	320–640 ³⁾ VDC	Output Amps	Voltage at load regulated to	Step-up voltage
E 3720	120 ²⁾	E 3730	E 3740	E 3750	E 3770	E 3780 Z	E 3770 G	150 ²⁾	depending on input voltage	0– 5.5
E 3721	80	E 3731	E 3741	E 3751	E 3771	E 3781 Z	E 3771 G	100		0– 10
E 3726	15	E 3736	E 3746	E 3756	E 3776	E 3786 Z	E 3776 G	18		0– 68
E 3727	8	E 3737	E 3747	E 3757	E 3777	E 3787 Z	E 3777 G	10		0– 130
E 3727 J	5	E 3737 J	E 3747 J	E 3757 J	E 3777 J	E 3787 ZJ	E 3777 GJ	6		0–200
E 3728	4	E 3738	E 3748	E 3758	E 3778	E 3788 Z	E 3778 G	5		0–250
E 3728 J	2.5	E 3738 J	E 3748 J	E 3758 J	E 3778 J	E 3788 ZJ	E 3778 GJ	3	0–400	

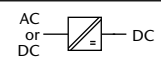

DC / DC Converters, AC / DC Power Supplies & Battery Chargers

- **DC Input voltage:** from 80 - 800V DC
- **AC Input voltage:** 115 / 230V AC, single phase or 200 / 400 / 480V AC, three phases
- **AC Input frequency:** 47 - 400Hz
- **Output voltage:** 5 / ... / 800V DC
- **Output current:** up to 800A
- **Output power:** 5 - 40kW

Features

- Input / Output isolation
- Continuous short circuit protection
- Overvoltage protection
- Thermal shutdown with auto-restart
- Operational from - 40 to +75 °C
- Industrial grade components
- High efficiency through ZVS topology
- High power density
- Compact and robust design
- Fan or liquid cooled



Specifications

Input

Voltage range	narrowing of input voltage range optimizes the efficiency (pls. specify); unit switches off at under- and overvoltage
No-load input power	30W typical
Switch-on time	<1s typical
Inrush current	3-phase AC input: limited by thermistor (except for series 55xx, 64xx, 66xx, 67xx & CW/BW56xx)
Immunity	acc. to EN 61000-6-2

Output

DC output voltages	5 9 12 15 24 28 48 60 110 200 220 400 600 800
Output power	from 5 to 40kW
Line regulation (±10%)	0.1%
Load regulation (10-90%)	0.2%
Load transient (10-90-10%)	6 % typical
Response time to ±1 %	10 ms typical
Turn-on rise time	Soft-start, 300 ms typical
Ripple	≤ 1% + 30 mV p-p
Overload protection	current limited to 105-110% of I _{nom}
Overvoltage protection	OVP switches off module with automatic return to operation; after 5 seconds, the unit will remain latched off

Remote sense	standard for all series up to 150 V output, except for battery chargers; up to 10 % of U _{nom} for output < 60 VDC, up to 6 V for output > 60 VDC
--------------	--

General

Efficiency	80 - 95% typical
Operating temperature	-20 to +75°C optional: -40 to +75°C
Load derating	2.5%/°C above + 55°C
Storage temperature	-40 to + 85°C
Cooling	☼ = fan cooled 💧 = liquid cooled <i>(details see page 131)</i>
Humidity	up to 95 % RH, non-condensing
Temperature coefficient	0.02 % / °C typical
Safety / Construction	acc. to EN 60950-1 / EN 50178
Protection category	IP20 acc. to EN 60529, NEMA or others upon request
EMI	acc. to EN 61000-6-4, class A, optionally class B
MTBF	approx. 70,000h @ 40°C acc. to MIL - HDBK - 217E (notice 1)
Connectors	terminals / bolts / bars or CombiTacs for Series 5100 <i>(details see page 132)</i>

Options (details see page 115)

Input

- Inrush current limiting
- Reverse polarity protection for DC input

Output

- Decoupling diode for redundant / parallel operation
- Active current sharing for parallel operation
- Remote on / off (inhibit)
- Reducing of current limiting at high ambient temperature

Signals

- via relay contacts
- Power ok (input)
- DC ok (output)

Monitoring

- of input / output voltage or current via
- analog signal
- interface card RS232 or CAN Bus

Programming

- of output voltage or current via
- potentiometer
- analog signal
- interface card RS232 or CAN Bus

Programming of battery chargers

- Temperature compensated charging voltage
- Automatic / manual selection of charging characteristic

Mechanics / environment:

- Wall mount
- Digital or analog V- and A-meter
- Increased mechanical strength
- Tropical protection
- Extended temperature range to -40 °C

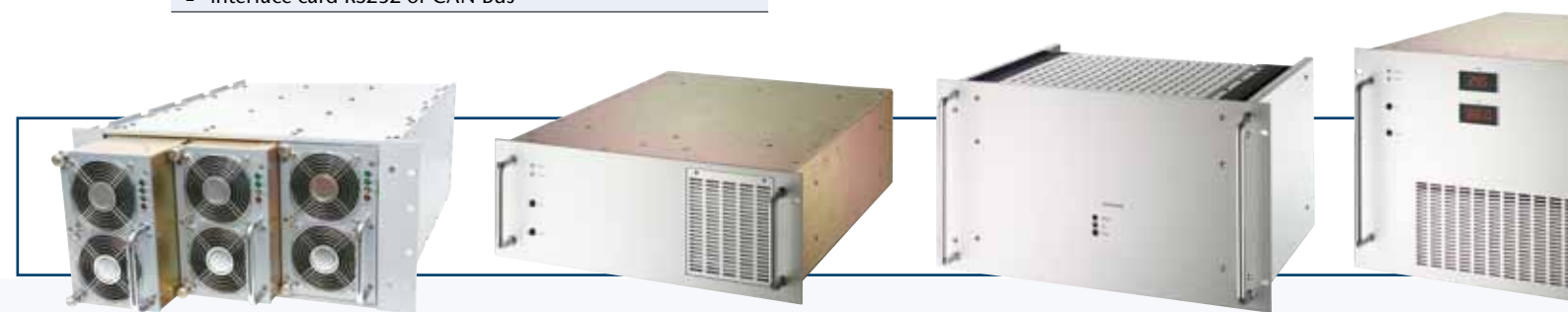

Selector Guide

Series	Output Power						DC input				AC input		nominal DC output voltage											Package			Cooling		Page								
	[kW]	2-6 kW	6-8 kW	8-10 kW	10-15 kW	15-30 kW	30-40 kW	[V]	80-160 V	160-320 V	320-380 V	320-640 V	450-800 V	1-phase	3-phase	[V]	5 V	9 V	12 V	15 V	24 V	28 V	48 V	60 V	110 V	200 V	220 V	400 V		600 V ¹⁾	800 V ¹⁾	Euro-cassette / 19" Rack mount Height [U]	19" Plug-in module Height [U]	Wall mount	Fan cooled	Liquid cooled	
C/B 5100	2.4-5						320-800									24 / 28 / ... / 200														3 / 5	4					53	
C/B 5200	4-5						80-800									5 / 9 / ... / 400															4					55	
C/B 5600	4.5-6						80-800									5 / 9 / ... / 400															6 / 9					57	
C/B 5300	5.6-7.5						80-800									12 / 24 / ... / 400															4					59	
C/B 5700	6.5-8						80-800									12 / 24 / ... / 400															6 / 9					61	
C/B 5400	7.5-10						80-800									24 / 28 / ... / 400															4					63	
C/B 5800	8.5-12						80-800									12 / 24 / ... / 400															6 / 9					65	
C/B 6400	20-22						320-800									48 / 60 / ... / 800															8					67	
C/B 6600	20-30						320-800									24 / 48 / ... / 800															10					69	
CW/BW 5300	5.6-8						80-800									12 / 24 / ... / 400															5					71	
CW/BW 5400	5.6-10						320-800									12 / 24 / ... / 400															3					73	
CW/BW 5500	7.5-15						80-800									24 / 28 / ... / 400																5					75
CW/BW 5600	9.1-20						320-800									24 / 28 / ... / 400																5					77
CW/BW 6600	24-30						320-800									48 / 60 / ... / 800																9					79
CW/BW 6700	20-40						320-800									24 / 48 / ... / 800																10					81
Step-Up Converters	2.4-40						80-800									80 / ... / 800															depending on module					83	

¹⁾ value (adjustable) to be advised

Further Information

Order example

Assistance in table use:

- 1 Select the column for input voltage range.
- 2 Select the row for the appropriate output voltage.
- 3 The intersection of both results in the module required.

For example:

- 1 input voltage = 160 - 320 VDC
- 2 output voltage = 60 VDC @ 110 A
- 3 results in a C 5376 module.

5.6 kW		7.5 kW							
		Input VDC					Output VDC		
80-160 VDC	Output Amps	160-320 VDC	320-380 ¹⁾ VDC	320-640 VDC	450-800 VDC	Output Amps	Adj.	Range	
C 5353	350	C 5373	C 5383 Z	C 5373 G	C 5373 K	350	15	14- 16	
C 5354	216	C 5374	C 5384 Z	C 5374 G	C 5374 K	288	24	23- 26	
C 5355	187	C 5375	C 5385 Z	C 5375 G	C 5375 K	250	28	26- 30	
C 5359	102	C 5379	C 5389 Z	C 5379 G	C 5379 K	136	48	45- 55	
C 5356	83	C 5376	C 5386 Z	C 5376 G	C 5376 K	110	60	58- 68	
C 5357	43	C 5377	C 5387 Z	C 5377 G	C 5377 K	58	110	100- 130	
C 5357 J	28	C 5377 J	C 5387 ZJ	C 5377 GJ	C 5377 KJ	38	200	190- 200	
C 5358	22.5	C 5378	C 5388 Z	C 5378 G	C 5378 K	30	220	200- 250	
C 5358 J	14	C 5378 J	C 5388 ZJ	C 5378 GJ	C 5378 KJ	19	400	380- 400	

Conversion table

Height:	1 U = 44.45 mm
	1 U = 1.75"
Width:	1 TE = 5.08 mm
	1 TE = 0.2"
	1" = 25.4 mm
	19" = 483 mm
Weight:	1 kg = 2.2 lbs

Conversion diagram °C > °F

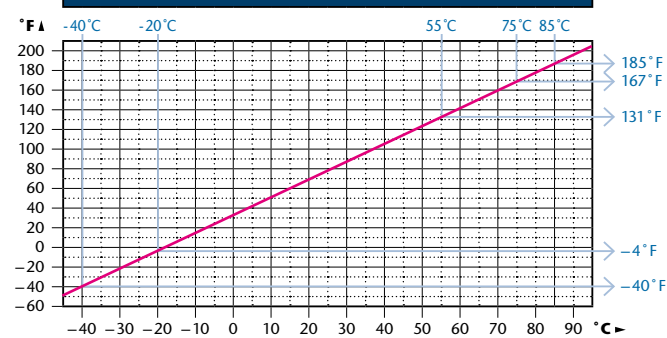

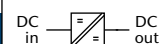

DC / DC Converters

▶ 5 kW						
Input VDC			Output Amps	Cooling	Output VDC	
320–380 ¹⁾ VDC	320–640 VDC	450–800 VDC			Adj.	Range
C 5184 Z	C 5174 G	C 5174 K	100	☼	24	23– 26
C 5185 Z	C 5175 G	C 5175 K	100	☼	28	26– 30
C 5189 Z	C 5179 G	C 5179 K	91	☼	48	45– 55
C 5186 Z	C 5176 G	C 5176 K	74	☼	60	58– 68
C 5187 Z	C 5177 G	C 5177 K	39	☼	110	100– 130
C 5187 ZJ	C 5177 GJ	C 5177 KJ	25	☼	200	190– 200

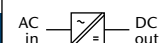

AC / DC Power Supplies

▶ 5 kW						
Input VAC, 3-Phase		Output Amps	Cooling	Output VDC		
3x400 ^{+15%} _{-20%}	3x480 ^{+10%} _{-15%}			Adj.	Range	
C 5184 V	C 5194 V	100	☼	24	23– 26	
C 5185 V	C 5195 V	100	☼	28	26– 30	
C 5189 V	C 5199 V	91	☼	48	45– 55	
C 5186 V	C 5196 V	74	☼	60	58– 68	
C 5187 V	C 5197 V	39	☼	110	100– 130	
C 5187 VJ	C 5197 VJ	25	☼	200	190– 200	

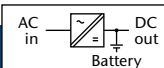

Battery Chargers

▶ 5 kW						
Input VAC, 3-Phase		Output Amps	Cooling	Output VDC		
3x400 ^{+15%} _{-20%}	3x480 ^{+10%} _{-15%}			Nom. Battery Voltage	Range	
B 5182 V	B 5192 V	100	☼	24	24– 32	
B 5184 V	B 5194 V	80	☼	48	48– 64	
B 5186 V	B 5196 V	62	☼	60	60– 80	
B 5187 V	B 5197 V	34	☼	110	110– 145	

Series specific information

Input

- Hold-up time for AC input: 5ms typical @ nom. input voltage
- ¹⁾ input supply from PFC also suitable

General

- optional: Cooling via speed-controlled fans (depending on temperature)
- optional: 19" sub-rack (3U or 5U) with terminals / bolts / bars
- ☼ = incl. fans



5U

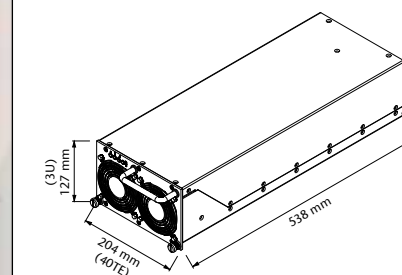

Standard

Pluggable module (for 3U sub-rack)

approx. 17 kg



Optional

3U, 19" sub-rack with 2 modules

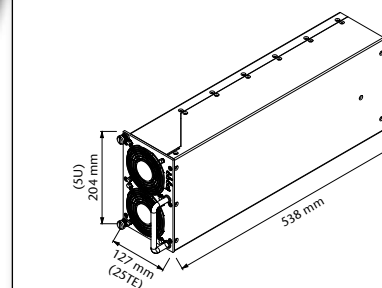

Standard

Pluggable module (for 5U sub-rack)

approx. 17 kg



Optional

5U, 19" sub-rack with 3 modules

Series C / B 5200

www.schaeferpower.de



DC / DC Converters

4 kW			5 kW				Cooling	Output VDC	
Input VDC								Adj.	Range
80-160 VDC	Output Amps	160-320 VDC	320-380 ¹⁾ VDC	320-640 VDC	450-800 VDC	Output Amps			
C 5250	350	C 5270	C 5280 Z	C 5270 G	C 5270 K	350	5	4.5- 5.5	
C 5251	350	C 5271	C 5281 Z	C 5271 G	C 5271 K	350	9	8- 10	
C 5252	305	C 5272	C 5282 Z	C 5272 G	C 5272 K	350	12	11- 13	
C 5253	250	C 5273	C 5283 Z	C 5273 G	C 5273 K	310	15	14- 16	
C 5254	154	C 5274	C 5284 Z	C 5274 G	C 5274 K	192	24	23- 26	
C 5255	133	C 5275	C 5285 Z	C 5275 G	C 5275 K	167	28	26- 30	
C 5259	73	C 5279	C 5289 Z	C 5279 G	C 5279 K	91	48	45- 55	
C 5256	59	C 5276	C 5286 Z	C 5276 G	C 5276 K	74	60	58- 68	
C 5257	31	C 5277	C 5287 Z	C 5277 G	C 5277 K	39	110	100- 130	
C 5257 J	20	C 5277 J	C 5287 ZJ	C 5277 GJ	C 5277 KJ	25	200	190-200	
C 5258	16	C 5278	C 5288 Z	C 5278 G	C 5278 K	20	220	200-250	
C 5258 J	10	C 5278 J	C 5288 ZJ	C 5278 GJ	C 5278 KJ	12.5	400	380-400	
C 5257H	6.66	C 5277 H	C 5287ZH	C 5277GH	C 5277KH	8.5	tba ²⁾	570-600	
C 5258H	5	C 5278 H	C 5288ZH	C 5278GH	C 5278KH	6.5	tba ²⁾	760-800	

new
Higher voltage upon request



AC / DC Power Supplies

5 kW			Output Amps	Cooling	Output VDC	
Input VAC, 3-Phase					Adj.	Range
3x200 ^{+15%} _{-20%}	3x400 ^{+15%} _{-20%}	3x480 ^{+10%} _{-15%}				
C 5260 V	C 5280 V	C 5290 V	350	5	4.5- 5.5	
C 5261 V	C 5281 V	C 5291 V	350	9	8- 10	
C 5262 V	C 5282 V	C 5292 V	350	12	11- 13	
C 5263 V	C 5283 V	C 5293 V	310	15	14- 16	
C 5264 V	C 5284 V	C 5294 V	192	24	23- 26	
C 5265 V	C 5285 V	C 5295 V	167	28	26- 30	
C 5269 V	C 5289 V	C 5299 V	91	48	45- 55	
C 5266 V	C 5286 V	C 5296 V	74	60	58- 68	
C 5267 V	C 5287 V	C 5297 V	39	110	100- 130	
C 5267 VJ	C 5287 VJ	C 5297 VJ	25	200	190-200	
C 5268 V	C 5288 V	C 5298 V	20	220	200-250	
C 5268 VJ	C 5288 VJ	C 5298 VJ	12.5	400	380-400	
C 5267VH	C 5287VH	C 5297VH	8.5	tba ²⁾	570-600	
C 5268VH	C 5288VH	C 5298VH	6.5	tba ²⁾	760-800	

new
Higher voltage upon request

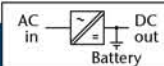

Battery Chargers

5 kW			Output Amps	Cooling	Output VDC	
Input VAC, 3-Phase					Nom. Battery Voltage	Range
3x200 ^{+15%} _{-20%}	3x400 ^{+15%} _{-20%}	3x480 ^{+10%} _{-15%}				
B 5261 V	B 5281 V	B 5291 V	310	12	12- 16	
B 5262 V	B 5282 V	B 5292 V	160	24	24- 32	
B 5264 V	B 5284 V	B 5294 V	80	48	48- 64	
B 5266 V	B 5286 V	B 5296 V	62	60	60- 80	
B 5267 V	B 5287 V	B 5297 V	34	110	110- 145	
B 5268 V	B 5288 V	B 5298 V	17	220	220-290	
B 5266VH	B 5286VH	B 5296VH	12.5	tba ²⁾	380-400	
B 5267VH	B 5287VH	B 5297VH	8.5	tba ²⁾	570-600	
B 5268VH	B 5288VH	B 5298VH	6.5	tba ²⁾	760-800	

new
Higher voltage upon request

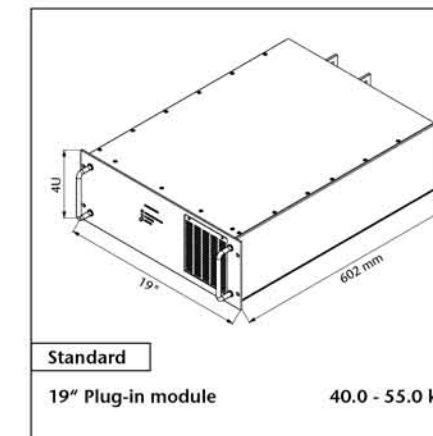

4U



Series specific information

Input

- Hold-up time for AC input: 5ms typical @ nom. input voltage

¹⁾ input supply from PFC also suitable

General

- optional: Cooling via speed-controlled fans (depending on temperature)

• = incl. temperature controlled fans

²⁾ tba = to be advised



DC / DC Converters

▶ 6 KW						Cooling	Output VDC	
Input VDC							Adj.	Range
80-160 VDC	160-320 VDC	320-380 ¹⁾ VDC	320-640 VDC	450-800 VDC	Output Amps			
▲ C 5650	▲ C 5670	▲ C 5680 Z	▲ C 5670 G	▲ C 5670 K	400	●	5	4.5- 5.5
▲ C 5651	▲ C 5671	▲ C 5681 Z	▲ C 5671 G	▲ C 5671 K	400	●	9	8- 10
▲ C 5652	▲ C 5672	▲ C 5682 Z	▲ C 5672 G	▲ C 5672 K	400	●	12	11- 13
▲ C 5653	▲ C 5673	▲ C 5683 Z	▲ C 5673 G	▲ C 5673 K	375	●	15	14- 16
● C 5654	● C 5674	● C 5684 Z	● C 5674 G	● C 5674 K	230	●	24	23- 26
● C 5655	● C 5675	● C 5685 Z	● C 5675 G	● C 5675 K	200	●	28	26- 30
● C 5659	● C 5679	● C 5689 Z	● C 5679 G	● C 5679 K	110	●	48	45- 55
● C 5656	● C 5676	● C 5686 Z	● C 5676 G	● C 5676 K	88	●	60	58- 68
● C 5657	● C 5677	● C 5687 Z	● C 5677 G	● C 5677 K	46	●	110	100- 130
● C 5657 J	● C 5677 J	● C 5687 ZJ	● C 5677 GJ	● C 5677 KJ	30	●	200	190-200
● C 5658	● C 5678	● C 5688 Z	● C 5678 G	● C 5678 K	24	●	220	200-250
● C 5658 J	● C 5678 J	● C 5688 ZJ	● C 5678 GJ	● C 5678 KJ	15	●	400	380-400
● C 5657 H	● C 5677 H	● C 5687 ZH	● C 5677 GH	● C 5677 KH	10	●	tba ²⁾	570-600
● C 5658 H	● C 5678 H	● C 5688 ZH	● C 5678 GH	● C 5678 KH	7.5	●	tba ²⁾	760-800

new
Higher voltage upon request



AC / DC Power Supplies

▶ 4.5 KW			▶ 6 KW				Cooling	Output VDC	
Input VAC, 1-Phase			Input VAC, 3-Phase					Adj.	Range
115 ±20%	Output Amps	230 ^{+15%} _{-20%}	3x200 ^{+15%} _{-20%}	3x400 ^{+15%} _{-20%}	3x480 ^{+10%} _{-15%}	Output Amps			
■ C 5660	400	■ C 5680	■ C 5660 V	■ C 5680 V	■ C 5690 V	400	●	5	4.5- 5.5
■ C 5661	380	■ C 5681	■ C 5661 V	■ C 5681 V	■ C 5691 V	400	●	9	8- 10
■ C 5662	310	■ C 5682	■ C 5662 V	■ C 5682 V	■ C 5692 V	400	●	12	11- 13
■ C 5663	265	■ C 5683	■ C 5663 V	■ C 5683 V	■ C 5693 V	375	●	15	14- 16
▼ C 5664	170	▼ C 5684	▼ C 5664 V	▼ C 5684 V	▼ C 5694 V	230	●	24	23- 26
▼ C 5665	150	▼ C 5685	▼ C 5665 V	▼ C 5685 V	▼ C 5695 V	200	●	28	26- 30
▼ C 5669	80	▼ C 5689	▼ C 5669 V	▼ C 5689 V	▼ C 5699 V	110	●	48	45- 55
▼ C 5666	65	▼ C 5686	▼ C 5666 V	▼ C 5686 V	▼ C 5696 V	88	●	60	58- 68
▼ C 5667	35	▼ C 5687	▼ C 5667 V	▼ C 5687 V	▼ C 5697 V	46	●	110	100- 130
▼ C 5667 J	22	▼ C 5687 J	▼ C 5667 VJ	▼ C 5687 VJ	▼ C 5697 VJ	30	●	200	190-200
▼ C 5668	18	▼ C 5688	▼ C 5668 V	▼ C 5688 V	▼ C 5698 V	24	●	220	200-250
▼ C 5668 J	11	▼ C 5688 J	▼ C 5668 VJ	▼ C 5688 VJ	▼ C 5698 VJ	15	●	400	380-400
▼ C 5667H	7.5	▼ C 5687H	▼ C5667VH	▼ C5687VH	▼ C5697VH	10	●	tba ²⁾	570-600
▼ C 5668H	5.625	▼ C 5688H	▼ C5668VH	▼ C5688VH	▼ C5698VH	7.5	●	tba ²⁾	760-800

new
Higher voltage upon request

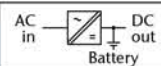

Battery Chargers

▶ 4.5 KW			▶ 6 KW				Cooling	Output VDC	
Input VAC, 1-Phase			Input VAC, 3-Phase					Nom. Battery Voltage	Range
115 ±20%	Output Amps	230 ^{+15%} _{-20%}	3x200 ^{+15%} _{-20%}	3x400 ^{+15%} _{-20%}	3x480 ^{+10%} _{-15%}	Output Amps			
■ B 5661	265	■ B 5681	■ B 5661 V	■ B 5681 V	■ B 5691 V	375	●	12	12- 16
▼ B 5662	140	▼ B 5682	▼ B 5662 V	▼ B 5682 V	▼ B 5692 V	190	●	24	24- 32
▼ B 5664	70	▼ B 5684	▼ B 5664 V	▼ B 5684 V	▼ B 5694 V	95	●	48	48- 64
▼ B 5666	55	▼ B 5686	▼ B 5666 V	▼ B 5686 V	▼ B 5696 V	75	●	60	60- 80
▼ B 5667	31	▼ B 5687	▼ B 5667 V	▼ B 5687 V	▼ B 5697 V	41	●	110	110- 145
▼ B 5668	16	▼ B 5688	▼ B 5668 V	▼ B 5688 V	▼ B 5698 V	21	●	220	220- 290
▼ B 5666H	11.25	▼ B 5686H	▼ B5666VH	▼ B5686VH	▼ B5696VH	15	●	tba ²⁾	380-400
▼ B 5667H	7.5	▼ B 5687H	▼ B5667VH	▼ B5687VH	▼ B5697VH	10	●	tba ²⁾	570-600
▼ B 5668H	5.625	▼ B 5688H	▼ B5668VH	▼ B5688VH	▼ B5698VH	7.5	●	tba ²⁾	760-800

new
Higher voltage upon request

Series specific information

Input

- Inrush current for 230V AC and 3-phase input: limited by thermistor
- Hold-up time for AC input: 5ms typical @ nom. input voltage
- ¹⁾input supply from PFC also suitable

General

- = incl. temperature controlled fans
- ²⁾ tba = to be advised



6U / 9U

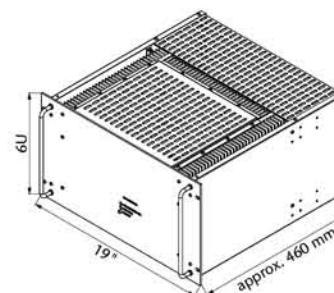

Standard
19" Plug-in module
● 35-50 kg ▼ 50-65 kg

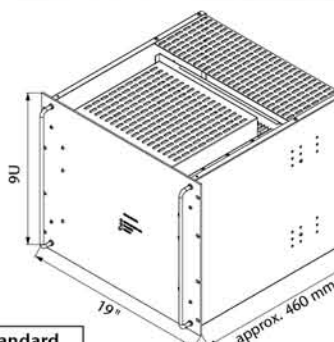

Standard
19" Plug-in module
▲ 50-65 kg ■ 65-75 kg

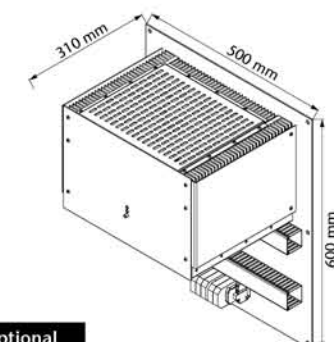

Optional
Wall mount
● 35-50 kg

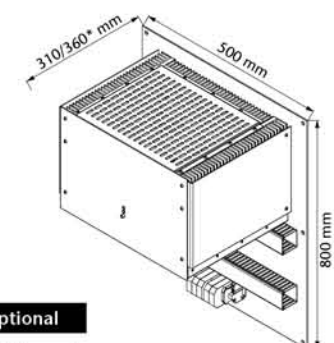

Optional
Wall mount
▼▲ 50-65 kg ■ 65-75 kg
*) applicable to output current > 350 A



DC / DC Converters

▶ 5.6 kW			▶ 7.5 kW				Cooling	Output VDC	
Input VDC								Adj.	Range
80-160 VDC	Output Amps	160-320 VDC	320-380 ¹⁾ VDC	320-640 VDC	450-800 VDC	Output Amps			
C 5353	350	C 5373	C 5383 Z	C 5373 G	C 5373 K	350	•	15	14- 16
C 5354	216	C 5374	C 5384 Z	C 5374 G	C 5374 K	288	•	24	23- 26
C 5355	187	C 5375	C 5385 Z	C 5375 G	C 5375 K	250	•	28	26- 30
C 5359	102	C 5379	C 5389 Z	C 5379 G	C 5379 K	136	•	48	45- 55
C 5356	83	C 5376	C 5386 Z	C 5376 G	C 5376 K	110	•	60	58- 68
C 5357	43	C 5377	C 5387 Z	C 5377 G	C 5377 K	58	•	110	100- 130
C 5357 J	28	C 5377 J	C 5387 ZJ	C 5377 GJ	C 5377 KJ	38	•	200	190- 200
C 5358	22.5	C 5378	C 5388 Z	C 5378 G	C 5378 K	30	•	220	200- 250
C 5358 J	14	C 5378 J	C 5388 ZJ	C 5378 GJ	C 5378 KJ	19	•	400	380- 400
C 5357H	9.5	C 5377H	C 5387ZH	C 5377GH	C 5377KH	12.5	•	tba ²⁾	570- 600
C 5358H	7	C 5378H	C 5388ZH	C 5378GH	C 5378KH	9.5	•	tba ²⁾	760- 800

new
Higher voltage upon request



AC / DC Power Supplies

▶ 7.5 kW						Cooling	Output VDC	
Input VAC, 3-Phase					Output Amps		Adj.	Range
3x200 ^{+15% -20%}	3x400 ^{+15% -20%}	3x480 ^{+10% -15%}						
C 5363 V	C 5383 V	C 5393 V	350	•	15	14- 16		
C 5364 V	C 5384 V	C 5394 V	288	•	24	23- 26		
C 5365 V	C 5385 V	C 5395 V	250	•	28	26- 30		
C 5369 V	C 5389 V	C 5399 V	136	•	48	45- 55		
C 5366 V	C 5386 V	C 5396 V	110	•	60	58- 68		
C 5367 V	C 5387 V	C 5397 V	58	•	110	100- 130		
C 5367 VJ	C 5387 VJ	C 5397 VJ	38	•	200	190- 200		
C 5368 V	C 5388 V	C 5398 V	30	•	220	200- 250		
C 5368 VJ	C 5388 VJ	C 5398 VJ	19	•	400	380- 400		
C 5367VH	C 5387VH	C 5397VH	12.5	•	tba ²⁾	570- 600		
C 5368VH	C 5388VH	C 5398VH	9.5	•	tba ²⁾	760- 800		

new
Higher voltage upon request



Battery Chargers

▶ 7.5 kW						Cooling	Output VDC	
Input VAC, 3-Phase					Output Amps		Nom. Battery Voltage	Range
3x200 ^{+15% -20%}	3x400 ^{+15% -20%}	3x480 ^{+10% -15%}						
B 5361 V	B 5381 V	B 5391 V	350	•	12	12- 16		
B 5362 V	B 5382 V	B 5392 V	235	•	24	24- 32		
B 5364 V	B 5384 V	B 5394 V	115	•	48	48- 64		
B 5366 V	B 5386 V	B 5396 V	93	•	60	60- 80		
B 5367 V	B 5387 V	B 5397 V	52	•	110	110- 145		
B 5368 V	B 5388 V	B 5398 V	26	•	220	220- 290		
B 5366VH	B 5386VH	B 5396VH	19	•	tba ²⁾	380- 400		
B 5367VH	B 5387VH	B 5397VH	12.5	•	tba ²⁾	570- 600		
B 5368VH	B 5388VH	B 5398VH	9.5	•	tba ²⁾	760- 800		

new
Higher voltage upon request

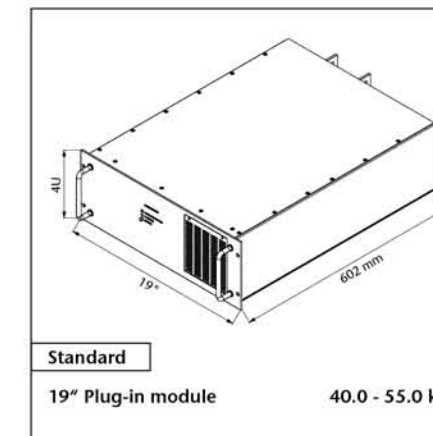

4U



Series specific information

Input

- Hold-up time for AC input: 4ms typical @ nom. input voltage

¹⁾ input supply from PFC also suitable

General

- optional: Cooling via speed-controlled fans (depending on temperature)

• = incl. fans

²⁾ tba = to be advised



DC / DC Converters

▶ 8 KW									
Input VDC						Cooling	Output VDC		
80-160 VDC	160-320 VDC	320-380 ¹⁾ VDC	320-640 VDC	450-800 VDC	Output Amps		Adj.	Range	
▲ C 5753	▲ C 5773	▲ C 5783 Z	▲ C 5773 G	▲ C 5773 K	400	●	15	14- 16	
▲ C 5754	▲ C 5774	▲ C 5784 Z	▲ C 5774 G	▲ C 5774 K	310	●	24	23- 26	
▲ C 5755	▲ C 5775	▲ C 5785 Z	▲ C 5775 G	▲ C 5775 K	270	●	28	26- 30	
▲ C 5759	● C 5779	● C 5789 Z	● C 5779 G	● C 5779 K	145	●	48	45- 55	
▲ C 5756	● C 5776	● C 5786 Z	● C 5776 G	● C 5776 K	120	●	60	58- 68	
▲ C 5757	● C 5777	● C 5787 Z	● C 5777 G	● C 5777 K	62	●	110	100- 130	
▲ C 5757 J	● C 5777 J	● C 5787 ZJ	● C 5777 GJ	● C 5777 KJ	40	●	200	190- 200	
▲ C 5758	● C 5778	● C 5788 Z	● C 5778 G	● C 5778 K	32	●	220	200- 250	
▲ C 5758 J	● C 5778 J	● C 5788 ZJ	● C 5778 GJ	● C 5778 KJ	20	●	400	380- 400	
▲ C 5757 H	● C 5777 H	● C 5787 H	● C 5777 GH	● C 5777 KH	13.5	●	tba ²⁾	570- 600	
▲ C 5758 H	● C 5778 H	● C 5788 H	● C 5778 GH	● C 5778 KH	10	●	tba ²⁾	760- 800	

new
Higher voltage upon request



AC / DC Power Supplies

▶ 6.5 KW				▶ 8 KW					
Input VAC, 1-Phase		Input VAC, 3-Phase				Output Amps	Cooling	Output VDC	
115 ±20%	Output Amps	230 ^{+15%} _{-20%}	3x200 ^{+15%} _{-20%}	3x400 ^{+15%} _{-20%}	3x480 ^{+10%} _{-15%}			Adj.	Range
■ C 5761	400	—	—	—	—	—	●	9	8- 10
■ C 5762	400	—	—	—	—	—	●	12	11- 13
■ C 5763	385	■ C 5783	■ C 5763 V	■ C 5783 V	■ C 5793 V	400	●	15	14- 16
■ C 5764	250	■ C 5784	■ C 5764 V	■ C 5784 V	■ C 5794 V	310	●	24	23- 26
■ C 5765	215	■ C 5785	■ C 5765 V	■ C 5785 V	■ C 5795 V	270	●	28	26- 30
■ C 5769	115	▼ C 5789	▼ C 5769 V	▼ C 5789 V	▼ C 5799 V	145	●	48	45- 55
■ C 5766	95	▼ C 5786	▼ C 5766 V	▼ C 5786 V	▼ C 5796 V	120	●	60	58- 68
■ C 5767	50	▼ C 5787	▼ C 5767 V	▼ C 5787 V	▼ C 5797 V	62	●	110	100- 130
■ C 5767 J	32	▼ C 5787 J	▼ C 5767 VJ	▼ C 5787 VJ	▼ C 5797 VJ	40	●	200	190- 200
■ C 5768	26	▼ C 5788	▼ C 5768 V	▼ C 5788 V	▼ C 5798 V	32	●	220	200- 250
■ C 5768 J	16	▼ C 5788 J	▼ C 5768 VJ	▼ C 5788 VJ	▼ C 5798 VJ	20	●	400	380- 400
■ C 5767 H	10.8	▼ C 5787 H	▼ C 5767 VH	▼ C 5787 VH	▼ C 5797 VH	13.5	●	tba ²⁾	570- 600
■ C 5768 H	8	▼ C 5788 H	▼ C 5768 VH	▼ C 5788 VH	▼ C 5798 VH	10	●	tba ²⁾	760- 800

new
Higher voltage upon request

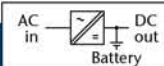

Battery Chargers

▶ 6.5 KW				▶ 8 KW					
Input VAC, 1-Phase		Input VAC, 3-Phase				Output Amps	Cooling	Output VDC	
115 ±20%	Output Amps	230 ^{+15%} _{-20%}	3x200 ^{+15%} _{-20%}	3x400 ^{+15%} _{-20%}	3x480 ^{+10%} _{-15%}			Nom. Battery Voltage	Range
■ B 5761	385	■ B 5781	■ B 5761 V	■ B 5781 V	■ B 5791 V	400	●	12	12- 16
■ B 5762	200	■ B 5782	■ B 5762 V	■ B 5782 V	■ B 5792 V	250	●	24	24- 32
■ B 5764	100	▼ B 5784	▼ B 5764 V	▼ B 5784 V	▼ B 5794 V	125	●	48	48- 64
■ B 5766	80	▼ B 5786	▼ B 5766 V	▼ B 5786 V	▼ B 5796 V	100	●	60	60- 80
■ B 5767	45	▼ B 5787	▼ B 5767 V	▼ B 5787 V	▼ B 5797 V	55	●	110	110- 145
■ B 5768	22	▼ B 5788	▼ B 5768 V	▼ B 5788 V	▼ B 5798 V	28	●	220	220- 290
■ B 5766H	16.25	▼ B 5786H	▼ B 5766 VH	▼ B 5786 VH	▼ B 5796 VH	20	●	tba ²⁾	380- 400
■ B 5767H	10.83	▼ B 5787H	▼ B 5767 VH	▼ B 5787 VH	▼ B 5797 VH	13.5	●	tba ²⁾	570- 600
■ B 5768H	8.125	▼ B 5788H	▼ B 5768 VH	▼ B 5788 VH	▼ B 5798 VH	10	●	tba ²⁾	760- 800

new
Higher voltage upon request

Series specific information

Input

- Hold-up time for AC input: 4ms typical @ nom. input voltage
- ¹⁾ input supply from PFC also suitable

General

- = incl. temperature controlled fans
- ²⁾ tba = to be advised



6U / 9U

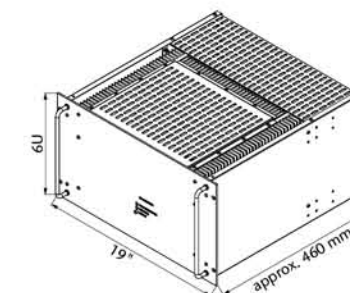

Standard
19" Plug-in module
● 35-50 kg ▼ 50-65 kg

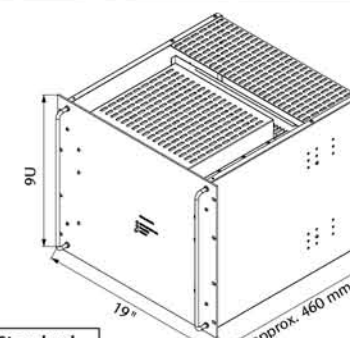

Standard
19" Plug-in module
▲ 50-65 kg ■ 65-75 kg

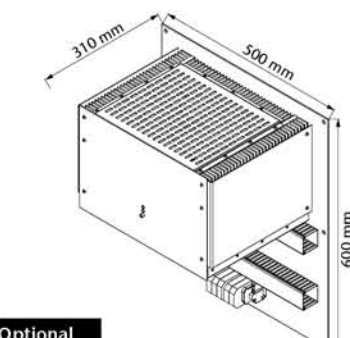

Optional
Wall mount
● 35-50 kg

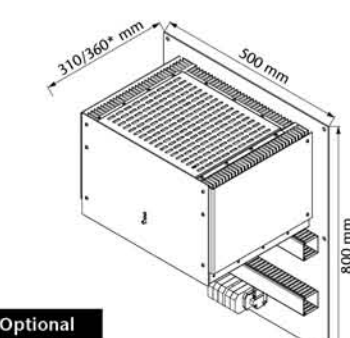

Optional
Wall mount
▼▲ 50-65 kg ■ 65-75 kg
*) applicable to output current > 350 A



DC / DC Converters

▶ 7.5 KW			▶ 10 KW				Cooling	Output VDC	
Input VDC								Adj.	Range
80-160 VDC	Output Amps	160-320 VDC	320-380 ¹⁾ VDC	320-640 VDC	450-800 VDC	Output Amps			
C 5454	288	C 5474	C 5484 Z	C 5474 G	C 5474 K	350	•	24	23- 26
C 5455	250	C 5475	C 5485 Z	C 5475 G	C 5475 K	330	•	28	26- 30
C 5459	136	C 5479	C 5489 Z	C 5479 G	C 5479 K	182	•	48	45- 55
C 5456	110	C 5476	C 5486 Z	C 5476 G	C 5476 K	147	•	60	58- 68
C 5457	58	C 5477	C 5487 Z	C 5477 G	C 5477 K	77	•	110	100- 130
C 5457 J	38	C 5477 J	C 5487 ZJ	C 5477 GJ	C 5477 KJ	50	•	200	190- 200
C 5458	30	C 5478	C 5488 Z	C 5478 G	C 5478 K	40	•	220	200- 250
C 5458 J	19	C 5478 J	C 5488 ZJ	C 5478 GJ	C 5478 KJ	25	•	400	380- 400
C 5457H	12.5	C 5477H	C 5487ZH	C 5477GH	C 5477KH	17	•	tba ²⁾	570- 600
C 5458H	9.375	C 5478H	C 5488ZH	C 5478GH	C 5478KH	12.5	•	tba ²⁾	760- 800

new
Higher voltage upon request



AC / DC Power Supplies

▶ 10 KW						Cooling	Output VDC	
Input VAC, 3-Phase					Output Amps		Adj.	Range
3x200 ^{+15%} _{-20%}	3x400 ^{+15%} _{-20%}	3x480 ^{+10%} _{-15%}						
C 5464 V	C 5484 V	C 5494 V			350	•	24	23- 26
C 5465 V	C 5485 V	C 5495 V			330	•	28	26- 30
C 5469 V	C 5489 V	C 5499 V			182	•	48	45- 55
C 5466 V	C 5486 V	C 5496 V			147	•	60	58- 68
C 5467 V	C 5487 V	C 5497 V			77	•	110	100- 130
C 5467 VJ	C 5487 VJ	C 5497 VJ			50	•	200	190- 200
C 5468 V	C 5488 V	C 5498 V			40	•	220	200- 250
C 5468 VJ	C 5488 VJ	C 5498 VJ			25	•	400	380- 400
C 5467VH	C 5487VH	C 5497VH			17	•	tba ²⁾	570- 600
C 5468VH	C 5488VH	C 5498VH			12.5	•	tba ²⁾	760- 800

new
Higher voltage upon request

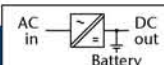

Battery Chargers

▶ 10 KW						Cooling	Output VDC	
Input VAC, 3-Phase					Output Amps		Nom. Battery Voltage	Range
3x200 ^{+15%} _{-20%}	3x400 ^{+15%} _{-20%}	3x480 ^{+10%} _{-15%}						
B 5462 V	B 5482 V	B 5492 V			320	•	24	24- 32
B 5464 V	B 5484 V	B 5494 V			160	•	48	48- 64
B 5466 V	B 5486 V	B 5496 V			130	•	60	60- 80
B 5467 V	B 5487 V	B 5497 V			70	•	110	110- 145
B 5468 V	B 5488 V	B 5498 V			35	•	220	220- 290
B 5466VH	B 5486VH	B 5496VH			25	•	tba ²⁾	380- 400
B 5467VH	B 5487VH	B 5497VH			17	•	tba ²⁾	570- 600
B 5468VH	B 5488VH	B 5498VH			12.5	•	tba ²⁾	760- 800

new
Higher voltage upon request

Series specific information

Input

- Hold-up time for AC input: 2.5ms typical @ nom. input voltage
- ¹⁾ input supply from PFC also suitable

General

- optional: Cooling via speed-controlled fans (depending on temperature)
- = incl. fans
- ²⁾ tba = to be advised

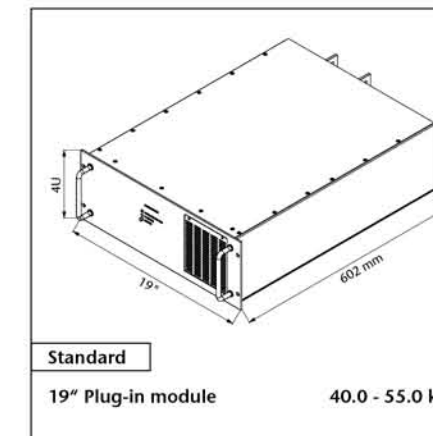

4U





DC / DC Converters

▶ 12 KW						Cooling	Output VDC	
Input VDC							Adj.	Range
80-160 VDC	160-320 VDC	320-380 ¹⁾ VDC	320-640 VDC	450-800 VDC	Output Amps			
▲ C 5854	▲ C 5874	▲ C 5884 Z	▲ C 5874 G	▲ C 5874 K	400	●	24	23- 26
▲ C 5855	▲ C 5875	▲ C 5885 Z	▲ C 5875 G	▲ C 5875 K	400	●	28	26- 30
▲ C 5859	▲ C 5879	● C 5889 Z	● C 5879 G	● C 5879 K	220	●	48	45- 55
▲ C 5856	▲ C 5876	● C 5886 Z	● C 5876 G	● C 5876 K	180	●	60	58- 68
▲ C 5857	▲ C 5877	● C 5887 Z	● C 5877 G	● C 5877 K	92	●	110	100- 130
▲ C 5857 J	▲ C 5877 J	● C 5887 ZJ	● C 5877 GJ	● C 5877 KJ	60	●	200	190- 200
▲ C 5858	▲ C 5878	● C 5888 Z	● C 5878 G	● C 5878 K	48	●	220	200- 250
▲ C 5858 J	▲ C 5878 J	● C 5888 ZJ	● C 5878 GJ	● C 5878 KJ	30	●	400	380- 400
▲ C 5857 H	▲ C 5877 H	● C 5887 ZH	● C 5877 GH	● C 5877 KH	20	●	tba ²⁾	570- 600
▲ C 5858 H	▲ C 5878 H	● C 5888 ZH	● C 5878 GH	● C 5878 KH	15	●	tba ²⁾	760- 800

new
Higher voltage upon request



AC / DC Power Supplies

▶ 8.5 KW			▶ 12 KW				Cooling	Output VDC	
Input VAC, 1-Phase			Input VAC, 3-Phase					Adj.	Range
115 ±20%	Output Amps	230 ^{+15%} _{-20%}	3x200 ^{+15%} _{-20%}	3x400 ^{+15%} _{-20%}	3x480 ^{+10%} _{-15%}	Output Amps			
■ C 5863	400	—	—	—	—	—	●	15	14- 16
■ C 5864	325	■ C 5884	■ C 5864 V	■ C 5884 V	■ C 5894 V	400	●	24	23- 26
■ C 5865	280	■ C 5885	■ C 5865 V	■ C 5885 V	■ C 5895 V	400	●	28	26- 30
■ C 5869	155	■ C 5889	■ C 5869 V	▼ C 5889 V	▼ C 5899 V	220	●	48	45- 55
■ C 5866	125	■ C 5886	■ C 5866 V	▼ C 5886 V	▼ C 5896 V	180	●	60	58- 68
■ C 5867	65	■ C 5887	■ C 5867 V	▼ C 5887 V	▼ C 5897 V	92	●	110	100- 130
■ C 5867 J	42	■ C 5887 J	■ C 5867 VJ	▼ C 5887 VJ	▼ C 5897 VJ	60	●	200	190- 200
■ C 5868	34	■ C 5888	■ C 5868 V	▼ C 5888 V	▼ C 5898 V	48	●	220	200- 250
■ C 5868 J	21	■ C 5888 J	■ C 5868 VJ	▼ C 5888 VJ	▼ C 5898 VJ	30	●	400	380- 400
■ C 5867H	14.16	■ C 5887H	■ C 5867VH	▼ C 5887VH	▼ C 5897VH	20	●	tba ²⁾	570- 600
■ C 5868H	10.63	■ C 5888H	■ C 5868VH	▼ C 5888VH	▼ C 5898VH	15	●	tba ²⁾	760- 800

new
Higher voltage upon request

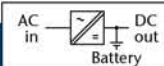

Battery Chargers

▶ 8.8 KW			▶ 12 KW				Cooling	Output VDC	
Input VAC, 1-Phase			Input VAC, 3-Phase					Nom. Battery Voltage	Range
115 ±20%	Output Amps	230 ^{+15%} _{-20%}	3x200 ^{+15%} _{-20%}	3x400 ^{+15%} _{-20%}	3x480 ^{+10%} _{-15%}	Output Amps			
■ B 5861	400	—	—	—	—	—	●	12	12- 16
■ B 5862	265	■ B 5882	■ B 5862 V	■ B 5882 V	■ B 5892 V	375	●	24	24- 32
■ B 5864	135	■ B 5884	■ B 5864 V	▼ B 5884 V	▼ B 5894 V	190	●	48	48- 64
■ B 5866	110	■ B 5886	■ B 5866 V	▼ B 5886 V	▼ B 5896 V	155	●	60	60- 80
■ B 5867	60	■ B 5887	■ B 5867 V	▼ B 5887 V	▼ B 5897 V	83	●	110	110- 145
■ B 5868	30	■ B 5888	■ B 5868 V	▼ B 5888 V	▼ B 5898 V	42	●	220	220- 290
■ B 5866H	22	■ B 5886H	■ B 5866VH	▼ B 5886VH	▼ B 5896VH	30	●	tba ²⁾	380- 400
■ B 5867H	14.66	■ B 5887H	■ B 5867VH	▼ B 5887VH	▼ B 5897VH	20	●	tba ²⁾	570- 600
■ B 5868H	11	■ B 5888H	■ B 5868VH	▼ B 5888VH	▼ B 5898VH	15	●	tba ²⁾	760- 800

new
Higher voltage upon request

Series specific information

Input

- Hold-up time for AC input: 2.5ms typical @ nom. input voltage
- ¹⁾ input supply from PFC also suitable

General

- = incl. temperature controlled fans
- ²⁾ tba = to be advised



6U / 9U

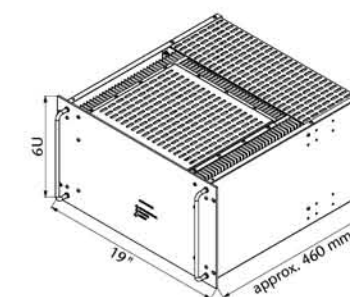

Standard

19" Plug-in module
● 35-50 kg ▼ 50-65 kg

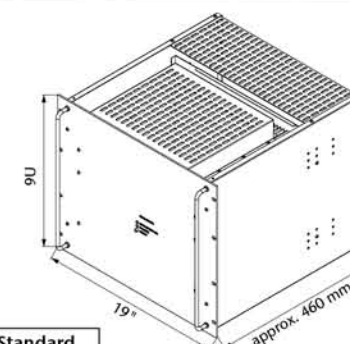

Standard

19" Plug-in module
▲ 50-65 kg ■ 65-75 kg

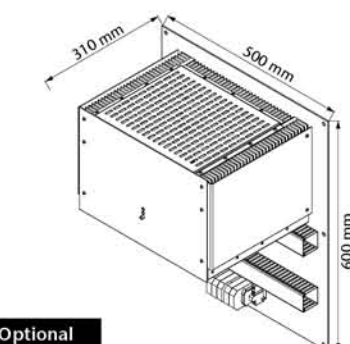

Optional

Wall mount
● 35-50 kg

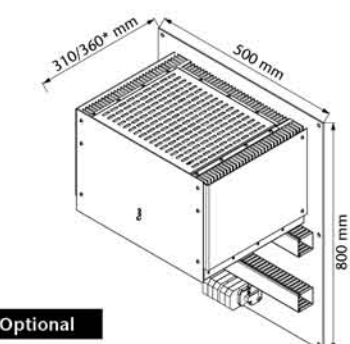

Optional

Wall mount
▼▲ 50-65 kg ■ 65-75 kg
*) applicable to output current > 350 A

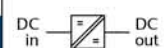

DC / DC Converters

▶ 22 KW					
Input VDC			Cooling	Output VDC	
320–640 VDC	450–800 VDC	Output Amps		Adj.	Range
C 6479 G	C 6479 K	360	•	48	45– 55
C 6476 G	C 6476 K	320	•	60	58– 68
C 6477 G	C 6477 K	170	•	110	100– 130
C 6477 GJ	C 6477 KJ	110	•	200	190– 200
C 6478 G	C 6478 K	88	•	220	200– 250
C 6478 GJ	C 6478 KJ	55	•	400	380– 400
C 6477 GH	C 6477 KH	37	•	tba ¹⁾	570– 600
C 6478 GH	C 6478 KH	28	•	tba ¹⁾	760– 800

Higher voltage upon request



AC / DC Power Supplies

▶ 22 KW					
Input VAC, 3-Phase		Output Amps	Cooling	Output VDC	
3x400 ^{+15%} _{-20%}	3x480 ^{+10%} _{-15%}			Adj.	Range
C 6489 V	C 6499 V	360	•	48	45– 55
C 6486 V	C 6496 V	320	•	60	58– 68
C 6487 V	C 6497 V	170	•	110	100– 130
C 6487 VJ	C 6497 VJ	110	•	200	190– 200
C 6488 V	C 6498 V	88	•	220	200– 250
C 6488 VJ	C 6498 VJ	55	•	400	380– 400
C 6487 VH	C 6497 VH	37	•	tba ¹⁾	570– 600
C 6488 VH	C 6498 VH	28	•	tba ¹⁾	760– 800

Higher voltage upon request

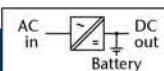

Battery Chargers

▶ 22 KW					
Input VAC, 3-Phase		Output Amps	Cooling	Output VDC	
3x400 ^{+15%} _{-20%}	3x480 ^{+10%} _{-15%}			Nom. Battery Voltage	Range
B 6484 V	B 6494 V	310	•	48	48– 64
B 6486 V	B 6496 V	270	•	60	60– 80
B 6487 V	B 6497 V	150	•	110	110– 145
B 6488 V	B 6498 V	75	•	220	220– 290
B 6486VH	B 6496VH	55	•	tba ¹⁾	380– 400
B 6487VH	B 6497VH	37	•	tba ¹⁾	570– 600
B 6488VH	B 6498VH	28	•	tba ¹⁾	760– 800

Higher voltage upon request

new

Series specific information

Input

- Hold-up time for AC input: 2.5ms typical @ nom. input voltage

General

- optional: Cooling via speed-controlled fans (depending on temperature)
- = incl. fans
- ¹⁾ tba = to be advised

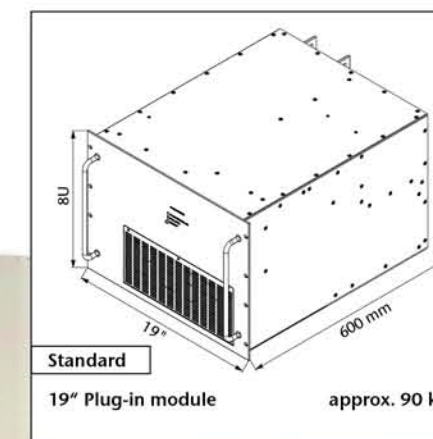

8U





DC / DC Converters

▶ 30 KW					
Input VDC			Cooling	Output VDC	
320–640 VDC	450–800 VDC	Output Amps		Adj.	Range
C 6674 G	C 6674 K	800	•	24	23– 26
C 6675 G	C 6675 K	800	•	28	26– 30
C 6679 G	C 6679 K	540	•	48	45– 55
C 6676 G	C 6676 K	440	•	60	58– 68
C 6677 G	C 6677 K	230	•	110	100– 130
C 6677 GJ	C 6677 KJ	150	•	200	190– 200
C 6678 G	C 6678 K	120	•	220	200– 250
C 6678 GJ	C 6678 KJ	75	•	400	380– 400
C 6677 GH	C 6677 KH	50	•	tba ¹⁾	570– 600
C 6678 GH	C 6678 KH	38	•	tba ¹⁾	760– 800

Higher voltage upon request



AC / DC Power Supplies

▶ 30 KW					
Input VAC, 3-Phase		Output Amps	Cooling	Output VDC	
3x400 ^{+15%} _{-20%}	3x480 ^{+10%} _{-15%}			Adj.	Range
C 6684 V	C 6694 V	800	•	24	23– 26
C 6685 V	C 6695 V	800	•	28	26– 30
C 6689 V	C 6699 V	540	•	48	45– 55
C 6686 V	C 6696 V	440	•	60	58– 68
C 6687 V	C 6697 V	230	•	110	100– 130
C 6687 VJ	C 6697 VJ	150	•	200	190– 200
C 6688 V	C 6698 V	120	•	220	200– 250
C 6688 VJ	C 6698 VJ	75	•	400	380– 400
C 6687 VH	C 6697 VH	50	•	tba ¹⁾	570– 600
C 6688 VH	C 6698 VH	38	•	tba ¹⁾	760– 800

Higher voltage upon request

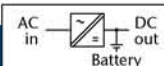

Battery Chargers

▶ 30 KW					
Input VAC, 3-Phase		Output Amps	Cooling	Output VDC	
3x400 ^{+15%} _{-20%}	3x480 ^{+10%} _{-15%}			Nom. Battery Voltage	Range
B 6682 V	B 6692 V	800	•	24	24– 32
B 6684 V	B 6694 V	468	•	48	48– 64
B 6686 V	B 6696 V	375	•	60	60– 80
B 6687 V	B 6697 V	208	•	110	110– 145
B 6688 V	B 6698 V	104	•	220	220– 290
B 6686VH	B 6696VH	75	•	tba ¹⁾	380– 400
B 6687VH	B 6697VH	50	•	tba ¹⁾	570– 600
B 6688VH	B 6698VH	38	•	tba ¹⁾	760– 800

Higher voltage upon request



Series specific information

Input

- Hold-up time for AC input: 2.5ms typical @ nom. input voltage

General

- optional: Cooling via speed-controlled fans (depending on temperature)
- = incl. fans
- ¹⁾ tba = to be advised

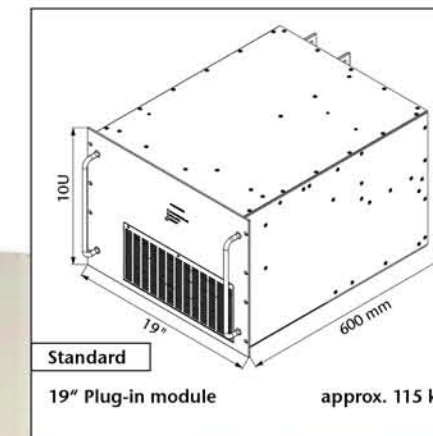

IOU





DC / DC Converters

5.6 kW			8 kW				Cooling	Output VDC	
Input VDC								Adj.	Range
80-160 VDC	Output Amps	160-320 VDC	320-380 ¹⁾ VDC	320-640 VDC	450-800 VDC	Output Amps			
CW 5353	350	CW 5373	CW 5383 Z	CW 5373 G	CW 5373 K	350	15	14- 16	
CW 5354	216	CW 5374	CW 5384 Z	CW 5374 G	CW 5374 K	310	24	23- 26	
CW 5355	187	CW 5375	CW 5385 Z	CW 5375 G	CW 5375 K	270	28	26- 30	
CW 5359	102	CW 5379	CW 5389 Z	CW 5379 G	CW 5379 K	146	48	45- 55	
CW 5356	83	CW 5376	CW 5386 Z	CW 5376 G	CW 5376 K	118	60	58- 68	
CW 5357	43	CW 5377	CW 5387 Z	CW 5377 G	CW 5377 K	62	110	100- 130	
CW 5357 J	28	CW 5377 J	CW 5387 ZJ	CW 5377 GJ	CW 5377 KJ	40	200	190- 200	
CW 5358	22.5	CW 5378	CW 5388 Z	CW 5378 G	CW 5378 K	32	220	200- 250	
CW 5358 J	14	CW 5378 J	CW 5388 ZJ	CW 5378 GJ	CW 5378 KJ	20	400	380- 400	
CW 5357H	9.33	CW 5377H	CW 5387ZH	CW 5377GH	CW 5377KH	13.5	tba ²⁾	570- 600	
CW 5358H	7	CW 5378H	CW 5388ZH	CW 5378GH	CW 5378KH	10	tba ²⁾	760- 800	

new

Higher voltage upon request

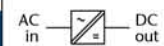

AC / DC Power Supplies

8 kW			Output Amps	Cooling	Output VDC	
Input VAC, 3-Phase					Adj.	Range
3x200 ^{+15%} _{-20%}	3x400 ^{+15%} _{-20%}	3x480 ^{+10%} _{-15%}				
CW 5363 V	CW 5383 V	CW 5393 V	350	15	14- 16	
CW 5364 V	CW 5384 V	CW 5394 V	310	24	23- 26	
CW 5365 V	CW 5385 V	CW 5395 V	270	28	26- 30	
CW 5369 V	CW 5389 V	CW 5399 V	146	48	45- 55	
CW 5366 V	CW 5386 V	CW 5396 V	118	60	58- 68	
CW 5367 V	CW 5387 V	CW 5397 V	62	110	100- 130	
CW 5367 VJ	CW 5387 VJ	CW 5397 VJ	40	200	190- 200	
CW 5368 V	CW 5388 V	CW 5398 V	32	220	200- 250	
CW 5368 VJ	CW 5388 VJ	CW 5398 VJ	20	400	380- 400	
CW 5367VH	CW 5387VH	CW 5397VH	13.5	tba ²⁾	570- 600	
CW 5368VH	CW 5388VH	CW 5398VH	10	tba ²⁾	760- 800	

new

Higher voltage upon request



Battery Chargers

8 kW			Output Amps	Cooling	Output VDC	
Input VAC, 3-Phase					Nom. Battery Voltage	Range
3x200 ^{+15%} _{-20%}	3x400 ^{+15%} _{-20%}	3x480 ^{+10%} _{-15%}				
BW 5361 V	BW 5381 V	BW 5391 V	350	12	12- 16	
BW 5362 V	BW 5382 V	BW 5392 V	250	24	24- 32	
BW 5364 V	BW 5384 V	BW 5394 V	125	48	48- 64	
BW 5366 V	BW 5386 V	BW 5396 V	100	60	60- 80	
BW 5367 V	BW 5387 V	BW 5397 V	56	110	110- 145	
BW 5368 V	BW 5388 V	BW 5398 V	28	220	220- 290	
BW5366VH	BW5386VH	BW5396VH	20	tba ²⁾	380- 400	
BW5367VH	BW5387VH	BW5397VH	13.5	tba ²⁾	570- 600	
BW5368VH	BW5388VH	BW5398VH	10	tba ²⁾	760- 800	

new

Higher voltage upon request

Series specific information

Input

- Hold-up time for AC input: 5ms typical @ nom. input voltage
- ¹⁾ input supply from PFC also suitable

General

- liquid cooled
- ²⁾ tba = to be advised

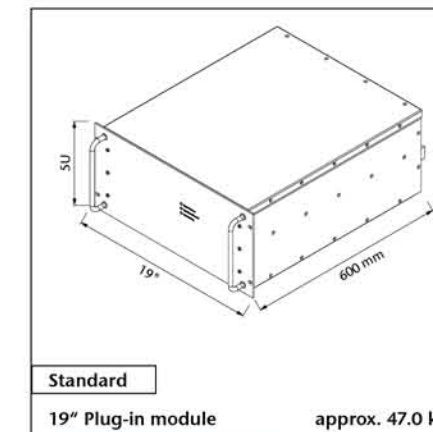

Standard
19" Plug-in module approx. 47.0 kg



rear view

5U





DC / DC Converters

▶ 10 kW						
Input VDC				Cooling	Output VDC	
320–380 ¹⁾ VDC	320–640 VDC	450–800 VDC	Output Amps		Adj.	Range
CW 5483 Z	CW 5473 G	CW 5473 K	350	🟢	15	14– 16
CW 5484 Z	CW 5474 G	CW 5474 K	350	🟢	24	23– 26
CW 5485 Z	CW 5475 G	CW 5475 K	330	🟢	28	26– 30
CW 5489 Z	CW 5479 G	CW 5479 K	180	🟢	48	45– 55
CW 5486 Z	CW 5476 G	CW 5476 K	147	🟢	60	58– 68
CW 5487 Z	CW 5477 G	CW 5477 K	76	🟢	110	100– 130
CW 5487 ZJ	CW 5477 GJ	CW 5477 KJ	50	🟢	200	190– 200
CW 5488 Z	CW 5478 G	CW 5478 K	40	🟢	220	200– 250
CW 5488 ZJ	CW 5478 GJ	CW 5478 KJ	25	🟢	400	380– 400
CW 5487ZH	CW5477GH	CW 5477KH	17	🟢	tba ²⁾	570– 600
CW 5488ZH	CW5478GH	CW 5478KH	12.5	🟢	tba ²⁾	760– 800

new

Higher voltage upon request



AC / DC Power Supplies

▶ 10 kW						
Input VAC, 3-Phase		Output Amps	Cooling	Output VDC		
3x400 ^{+15%} _{-20%}	3x480 ^{+10%} _{-15%}			Adj.	Range	
CW 5483 V	CW 5493 V	350	🟢	15	14– 16	
CW 5484 V	CW 5494 V	350	🟢	24	23– 26	
CW 5485 V	CW 5495 V	330	🟢	28	26– 30	
CW 5489 V	CW 5499 V	180	🟢	48	45– 55	
CW 5486 V	CW 5496 V	147	🟢	60	58– 68	
CW 5487 V	CW 5497 V	76	🟢	110	100– 130	
CW 5487 VJ	CW 5497 VJ	50	🟢	200	190– 200	
CW 5488 V	CW 5498 V	40	🟢	220	200– 250	
CW 5488 VJ	CW 5498 VJ	25	🟢	400	380– 400	
CW 5487VH	CW 5497VH	17	🟢	tba ²⁾	570– 600	
CW 5488VH	CW 5498VH	12.5	🟢	tba ²⁾	760– 800	

new

Higher voltage upon request

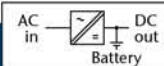

Battery Chargers

▶ 10 kW						
Input VAC, 3-Phase		Output Amps	Cooling	Output VDC		
3x400 ^{+15%} _{-20%}	3x480 ^{+10%} _{-15%}			Nom. Battery Voltage	Range	
BW 5481 V	BW 5491 V	350	🟢	12	12– 16	
BW 5482 V	BW 5492 V	312	🟢	24	24– 32	
BW 5484 V	BW 5494 V	156	🟢	48	48– 64	
BW 5486 V	BW 5496 V	125	🟢	60	60– 80	
BW 5487 V	BW 5497 V	68	🟢	110	110– 145	
BW 5488 V	BW 5498 V	34	🟢	220	220– 290	
BW5486VH	BW5496VH	25	🟢	tba ²⁾	380– 400	
BW5487VH	BW5497VH	17	🟢	tba ²⁾	570– 600	
BW5488VH	BW5498VH	12.5	🟢	tba ²⁾	760– 800	

new

Higher voltage upon request

Series specific information

Input

- Hold-up time for AC input:
5ms typical @ nom. input voltage
- ¹⁾input supply from PFC also suitable

General

- 🟢 = liquid cooled
- ²⁾ tba = to be advised

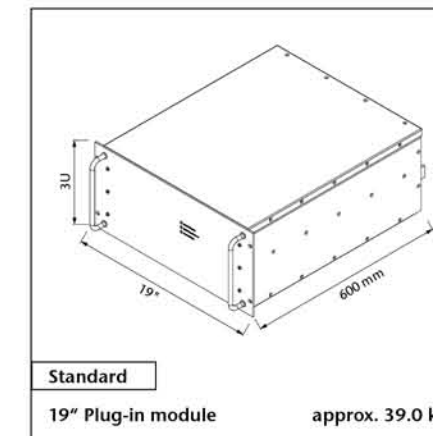

Standard
19" Plug-in module approx. 39.0 kg

3U





DC / DC Converters

▶ 7.5 KW			▶ 15 KW				Cooling	Output VDC	
Input VDC								Adj.	Range
80–160 VDC	Output Amps	160–320 VDC	320–380 ¹⁾ VDC	320–640 VDC	450–800 VDC	Output Amps			
CW 5554	288	CW 5574	CW 5584 Z	CW 5574 G	CW 5574 K	350	24	23– 26	
CW 5555	250	CW 5575	CW 5585 Z	CW 5575 G	CW 5575 K	350	28	26– 30	
CW 5559	136	CW 5579	CW 5589 Z	CW 5579 G	CW 5579 K	273	48	45– 55	
CW 5556	110	CW 5576	CW 5586 Z	CW 5576 G	CW 5576 K	220	60	58– 68	
CW 5557	58	CW 5577	CW 5587 Z	CW 5577 G	CW 5577 K	116	110	100– 130	
CW 5557 J	38	CW 5577 J	CW 5587 ZJ	CW 5577 GJ	CW 5577 KJ	75	200	190– 200	
CW 5558	30	CW 5578	CW 5588 Z	CW 5578 G	CW 5578 K	60	220	200– 250	
CW 5558 J	19	CW 5578 J	CW 5588 ZJ	CW 5578 GJ	CW 5578 KJ	38	400	380– 400	
CW5557H	12.5	CW5577H	CW5587ZH	CW5577GH	CW5577KH	25	tba ²⁾	570– 600	
CW5558H	9.375	CW5578H	CW5588ZH	CW5578GH	CW5578KH	19	tba ²⁾	760– 800	

NEW

Higher voltage upon request



AC / DC Power Supplies

▶ 15 KW			Output Amps	Cooling	Output VDC	
Input VAC, 3-Phase					Adj.	Range
3x200 ^{+15%} _{-20%}	3x400 ^{+15%} _{-20%}	3x480 ^{+10%} _{-15%}				
CW 5564 V	CW 5584 V	CW 5594 V	350	24	23– 26	
CW 5565 V	CW 5585 V	CW 5595 V	350	28	26– 30	
CW 5569 V	CW 5589 V	CW 5599 V	273	48	45– 55	
CW 5566 V	CW 5586 V	CW 5596 V	220	60	58– 68	
CW 5567 V	CW 5587 V	CW 5597 V	116	110	100– 130	
CW 5567 VJ	CW 5587 VJ	CW 5597 VJ	75	200	190– 200	
CW 5568 V	CW 5588 V	CW 5598 V	60	220	200– 250	
CW 5568 VJ	CW 5588 VJ	CW 5598 VJ	38	400	380– 400	
CW5567VH	CW5587VH	CW5597VH	25	tba ²⁾	570– 600	
CW5568VH	CW5588VH	CW5598VH	19	tba ²⁾	760– 800	

NEW

Higher voltage upon request

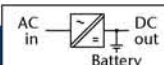

Battery Chargers

▶ 15 KW			Output Amps	Cooling	Output VDC	
Input VAC, 3-Phase					Nom. Battery Voltage	Range
3x200 ^{+15%} _{-20%}	3x400 ^{+15%} _{-20%}	3x480 ^{+10%} _{-15%}				
BW 5562 V	BW 5582 V	BW 5592 V	328	24	24– 32	
BW 5564 V	BW 5584 V	BW 5594 V	234	48	48– 64	
BW 5566 V	BW 5586 V	BW 5596 V	188	60	60– 80	
BW 5567 V	BW 5587 V	BW 5597 V	104	110	110– 145	
BW 5568 V	BW 5588 V	BW 5598 V	52	220	220– 290	
BW5566VH	BW5586VH	BW5596VH	37.5	tba ²⁾	380– 400	
BW5567VH	BW5587VH	BW5597VH	25	tba ²⁾	570– 600	
BW5568VH	BW5588VH	BW5598VH	19	tba ²⁾	760– 800	

NEW

Higher voltage upon request

Series specific information

Input

- Hold-up time for AC input: 5ms typical @ nom. input voltage
- ¹⁾ input supply from PFC also suitable

General

- Water = liquid cooled
- ²⁾ tba = to be advised

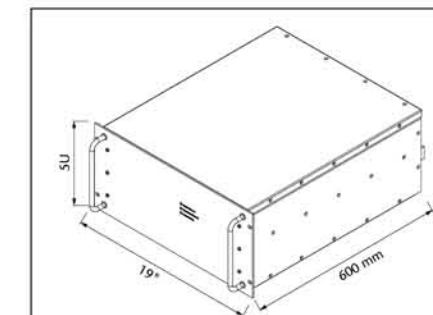

Standard

19" Plug-in module

approx. 47 kg



rear view

5U





DC / DC Converters

▶ 20 KW						
Input VDC				Cooling	Output VDC	
320–380 ¹⁾ VDC	320–640 VDC	450–800 VDC	Output Amps		Adj.	Range
CW 5684 Z	CW 5674 G	CW 5674 K	350	🟢	24	23– 26
CW 5685 Z	CW 5675 G	CW 5675 K	350	🟢	28	26– 30
CW 5689 Z	CW 5679 G	CW 5679 K	350	🟢	48	45– 55
CW 5686 Z	CW 5676 G	CW 5676 K	294	🟢	60	58– 68
CW 5687 Z	CW 5677 G	CW 5677 K	153	🟢	110	100– 130
CW 5687 ZJ	CW 5677 GJ	CW 5677 KJ	100	🟢	200	190– 200
CW 5688 Z	CW 5678 G	CW 5678 K	80	🟢	220	200– 250
CW 5688 ZJ	CW 5678 GJ	CW 5678 KJ	50	🟢	400	380– 400
CW 5687ZH	CW5677GH	CW5677KH	33.5	🟢	tba ²⁾	570– 600
CW 5688ZH	CW5678GH	CW5678KH	25	🟢	tba ²⁾	760– 800

new

Higher voltage upon request



AC / DC Power Supplies

▶ 20 KW					
Input VAC, 3-Phase		Output Amps	Cooling	Output VDC	
3x400 ^{+15%} –20%	3x480 ^{+10%} –15%			Adj.	Range
CW 5684 V	CW 5694 V	350	🟢	24	23– 26
CW 5685 V	CW 5695 V	350	🟢	28	26– 30
CW 5689 V	CW 5699 V	350	🟢	48	45– 55
CW 5686 V	CW 5696 V	294	🟢	60	58– 68
CW 5687 V	CW 5697 V	153	🟢	110	100– 130
CW 5687 VJ	CW 5697 VJ	100	🟢	200	190– 200
CW 5688 V	CW 5698 V	80	🟢	220	200– 250
CW 5688 VJ	CW 5698 VJ	50	🟢	400	380– 400
CW5687 VH	CW 5697VH	33.5	🟢	tba ²⁾	570– 600
CW5688 VH	CW 5698VH	25	🟢	tba ²⁾	760– 800

new

Higher voltage upon request

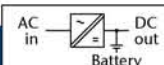

Battery Chargers

▶ 20 KW					
Input VAC, 3-Phase		Output Amps	Cooling	Output VDC	
3x400 ^{+15%} –20%	3x480 ^{+10%} –15%			Nom. Battery Voltage	Range
BW 5682 V	BW 5692 V	350	🟢	24	24– 32
BW 5684 V	BW 5694 V	312	🟢	48	48– 64
BW 5686 V	BW 5696 V	250	🟢	60	60– 80
BW 5687 V	BW 5697 V	137	🟢	110	110– 145
BW 5688 V	BW 5698 V	68	🟢	220	220– 290
BW5686VH	BW5696VH	50	🟢	tba ²⁾	380– 400
BW5687VH	BW5697VH	33.5	🟢	tba ²⁾	570– 600
BW5688VH	BW5698VH	25	🟢	tba ²⁾	760– 800

new

Higher voltage upon request

Series specific information

Input

- Hold-up time for AC input:
4ms typical @ nom. input voltage
¹⁾ input supply from PFC also suitable

General

- 🟢 = liquid cooled
²⁾ tba = to be advised

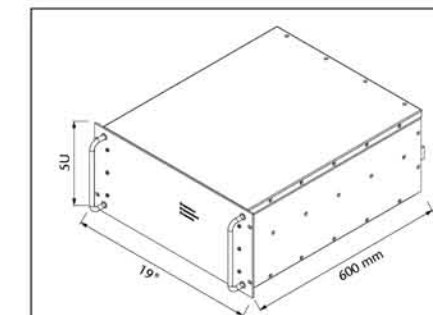

Standard

19" Plug-in module

approx. 47 kg



rear view

5U





DC / DC Converters

▶ 30 KW					
Input VDC			Cooling	Output VDC	
320-640 VDC	450-800 VDC	Output Amps		Adj.	Range
CW 6679 G	CW 6679 K	450	🟢	48	45- 55
CW 6676 G	CW 6676 K	442	🟢	60	58- 68
CW 6677 G	CW 6677 K	231	🟢	110	100- 130
CW 6677 GJ	CW 6677 KJ	150	🟢	200	190- 200
CW 6678 G	CW 6678 K	120	🟢	220	200- 250
CW 6678 GJ	CW 6678 KJ	75	🟢	400	380- 400
CW 6677 GH	CW 6677 KH	50	🟢	tba ¹⁾	570- 600
CW 6678 GH	CW 6678 KH	38	🟢	tba ¹⁾	760- 800

Higher voltage upon request



AC / DC Power Supplies

▶ 30 KW					
Input VAC, 3-Phase			Cooling	Output VDC	
3x400 ^{+15%} _{-20%}	3x480 ^{+10%} _{-15%}	Output Amps		Adj.	Range
CW 6689 V	CW 6699 V	450	🟢	48	45- 55
CW 6686 V	CW 6696 V	442	🟢	60	58- 68
CW 6687 V	CW 6697 V	231	🟢	110	100- 130
CW 6687 VJ	CW 6697 VJ	150	🟢	200	190- 200
CW 6688 V	CW 6698 V	120	🟢	220	200- 250
CW 6688 VJ	CW 6698 VJ	75	🟢	400	380- 400
CW 6687 VH	CW 6697 VH	50	🟢	tba ¹⁾	570- 600
CW 6688 VH	CW 6698 VH	38	🟢	tba ¹⁾	760- 800

Higher voltage upon request

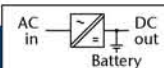

Battery Chargers

▶ 30 KW					
Input VAC, 3-Phase			Cooling	Output VDC	
3x400 ^{+15%} _{-20%}	3x480 ^{+10%} _{-15%}	Output Amps		Nom. Battery Voltage	Range
BW 6684 V	BW 6694 V	386	🟢	48	48- 64
BW 6686 V	BW 6696 V	375	🟢	60	60- 80
BW 6687 V	BW 6697 V	208	🟢	110	110- 145
BW 6688 V	BW 6698 V	104	🟢	220	220- 290
BW6686VH	BW6696VH	75	🟢	tba ²⁾	380- 400
BW6687VH	BW6697VH	50	🟢	tba ²⁾	570- 600
BW6688VH	BW6698VH	38	🟢	tba ²⁾	760- 800

Higher voltage upon request



Series specific information

Input

- Hold-up time for AC input: 5ms typical @ nom. input voltage

General

- 🟢 = liquid cooled
- ¹⁾ tba = to be advised

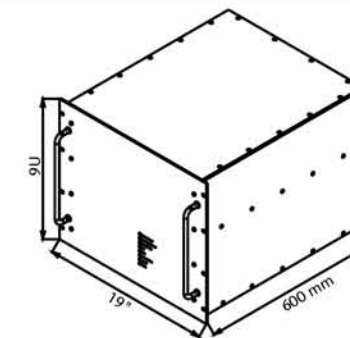

Standard
19" Plug-in module approx. 108 kg



rear view

9U



Voltage **125.0** Current **26**

- Output Voltage ok
- Input Voltage / Phase ok
- Current Limiting
- OVP
- 75 °C
- Overtemperature
- Interlock
- Failure



DC / DC Converters

▶ 40 KW					
Input VDC			Cooling	Output VDC	
320-640 VDC	450-800 VDC	Output Amps		Adj.	Range
CW 6774 G	CW 6774 K	800	🟢	24	23- 26
CW 6775 G	CW 6775 K	800	🟢	28	26- 30
CW 6779 G	CW 6779 K	720	🟢	48	45- 55
CW 6776 G	CW 6776 K	580	🟢	60	58- 68
CW 6777 G	CW 6777 K	305	🟢	110	100- 130
CW 6777 GJ	CW 6777 KJ	200	🟢	200	190- 200
CW 6778 G	CW 6778 K	160	🟢	220	200- 250
CW 6778 GJ	CW 6778 KJ	100	🟢	400	380- 400
CW 6777 GH	CW 6777 KH	67	🟢	tba ¹⁾	570- 600
CW 6778 GH	CW 6778 KH	50	🟢	tba ¹⁾	760- 800

Higher voltage upon request



AC / DC Power Supplies

▶ 40 KW					
Input VAC, 3-Phase		Output Amps	Cooling	Output VDC	
3x400 ^{+15%} _{-20%}	3x480 ^{+10%} _{-15%}			Adj.	Range
CW 6784 V	CW 6794 V	800	🟢	24	23- 26
CW 6785 V	CW 6795 V	800	🟢	28	26- 30
CW 6789 V	CW 6799 V	720	🟢	48	45- 55
CW 6786 V	CW 6796 V	580	🟢	60	58- 68
CW 6787 V	CW 6797 V	305	🟢	110	100- 130
CW 6787 VJ	CW 6797 VJ	200	🟢	200	190- 200
CW 6788 V	CW 6798 V	160	🟢	220	200- 250
CW 6788 VJ	CW 6798 VJ	100	🟢	400	380- 400
CW 6787 VH	CW 6797 VH	67	🟢	tba ¹⁾	570- 600
CW 6788 VH	CW 6798 VH	50	🟢	tba ¹⁾	760- 800

Higher voltage upon request

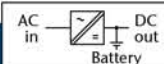

Battery Chargers

▶ 40 KW					
Input VAC, 3-Phase		Output Amps	Cooling	Output VDC	
3x400 ^{+15%} _{-20%}	3x480 ^{+10%} _{-15%}			Nom. Battery Voltage	Range
BW 6782 V	BW 6792 V	800	🟢	24	24- 32
BW 6784 V	BW 6794 V	625	🟢	48	48- 64
BW 6786 V	BW 6796 V	500	🟢	60	60- 80
BW 6787 V	BW 6797 V	275	🟢	110	110- 145
BW 6788 V	BW 6798 V	135	🟢	220	220- 290
BW6786VH	BW6796VH	100	🟢	tba ¹⁾	380- 400
BW6787VH	BW6797VH	67	🟢	tba ¹⁾	570- 600
BW6788VH	BW6798VH	50	🟢	tba ¹⁾	760- 800

Higher voltage upon request



Series specific information

Input

- Hold-up time for AC input: 4ms typical @ nom. input voltage

General

- ¹⁾ tba = to be advised
- 🟢 = liquid cooled

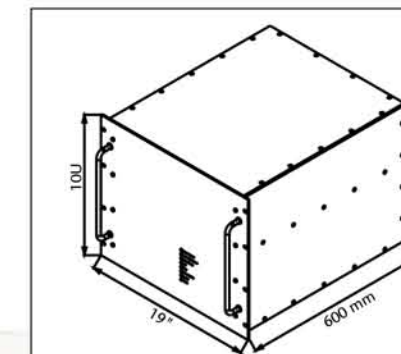

Standard
19" Plug-in module approx. 168 kg



rear view

IOU



Voltage: 125.0
Current: 26

- Output Voltage ok
- Input Voltage / Phase ok
- Current Limiting
- OVP
- 75 °C
- Overtemperature
- Interlock
- Failure

Step-up converters

The step-up converters are very similar to the DC/DC converters of series "C", except that the step-up converters sense the voltage across the load which is the total of the battery voltage and the voltage added by the step-up converter. The step-up converter can not reduce the voltage being applied to its input. Therefore, the load should be specified for the maximum battery voltage.

For output voltage stabilization

The output voltage of an e.g. battery charger with parallel connected battery varies substantially with the charging condition of the battery. For many applications, however, the load circuit requires a better stabilized voltage. Frequently used methods for reducing the voltage variation are e.g. "voltage dropping diodes". A more economical solution is given by switch mode step-up converters. These are DC/DC converters supplied from the battery with the output connected in series to the battery. Due to the circuit configuration, the output of a step-up converter is not isolated from the input supply (battery).



Operation diagram

- During normal operation no voltage needs to be added and the converter runs with a minimum of power losses. The voltage at the load is slightly reduced as the current flows through the bypass diode. The bypass diode also allows for replacement of the step-up converter and should therefore be installed externally.
- During battery discharge the converter adds the voltage that is needed to maintain the required output voltage level.
- The maximum voltage to be added is normally less than 20 % of the total voltage. Therefore, the step-up converter needs to be designed for 20 % of the through-power, only.

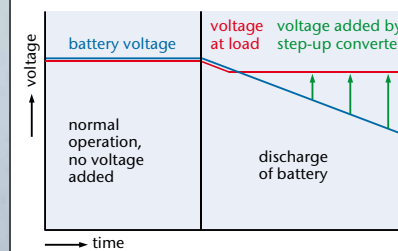

Example:
 ■ Input: 40 – 56 VDC (battery)
 ■ Output: 0 – 10 VDC (step-up voltage)
 output voltage regulated to 50 V during discharge of battery

Circuit diagrams

Step-up converter with common positive line

The following circuit diagram shows a step-up converter which can be grounded on the positive side. The voltage will be added at the negative side and the positive line is common for input and output.

Step-up converter with common negative line

The following circuit diagram shows a step-up converter which can be grounded on the negative side. The voltage will be added at the positive side and the negative line is common for input and output.

Parallel operation of step-up converters

For more power or redundancy step-up converters may be connected in parallel with active current sharing, individually protected by fuses at the input and decoupling diodes or fuses at the output. Such systems have already been realized for 2,000 Amps.

Individual load supply

For applications that require individually stabilized voltages across the loads, the step-converters will be connected as shown in the following diagram and may be of different power ratings.

Create your step-up converter

- Each DC/DC converter can be modified to be a step-up converter:
- calculate the output power of the step-up converter: max. voltage to be added x max. load current
 - choose the suitable "C" series & re-name the model as "E" ...

▶ 5.6 kW		▶ 7.5 kW						
		Input VDC					Output VDC	
80–160 VDC	Output Amps	160–320 VDC	320–380 ¹⁾ VDC	320–640 VDC	450–800 VDC	Output Amps	Adj.	Range
C 5353	350	C 5373	C 5383 Z	C 5373 G	C 5373 K	350	15	14– 16
C 5354	216	C 5374	C 5384 Z	C 5374 G	C 5374 K	288	24	23– 26
C 5355	187	C 5375	C 5385 Z	C 5375 G	C 5375 K	250	28	26– 30
C 5359	102	C 5379	C 5389 Z	C 5379 G	C 5379 K	136	48	45– 55
C 5356	83	C 5376	C 5386 Z	C 5376 G	C 5376 K	110	60	58– 68
C 5357	43	C 5377	C 5387 Z	C 5377 G	C 5377 K	58	110	100– 130
C 5357 J	28	C 5377 J	C 5387 ZJ	C 5377 GJ	C 5377 KJ	38	200	190– 200
C 5358	22.5	C 5378	C 5388 Z	C 5378 G	C 5378 K	30	220	200– 250
C 5358 J	14	C 5378 J	C 5388 ZJ	C 5378 GJ	C 5378 KJ	19	400	380– 400

Example:

Step-up Converters

▶ 5.6 kW		▶ 7.5 kW						
		Input VDC (battery voltage)					Output VDC	
80–160 VDC	Output Amps	160–320 VDC	320–380 ¹⁾ VDC	320–640 VDC	450–800 VDC	Output Amps	Voltage at load regulated to	Step-up voltage
E 5353	350	E 5373	E 5383 Z	E 5373 G	E 5373 K	350	depending on input voltage	0– 16
E 5354	216	E 5374	E 5384 Z	E 5374 G	E 5374 K	288		0– 26
E 5355	187	E 5375	E 5385 Z	E 5375 G	E 5375 K	250		0– 30
E 5359	102	E 5379	E 5389 Z	E 5379 G	E 5379 K	136		0– 55
E 5356	83	E 5376	E 5386 Z	E 5376 G	E 5376 K	110		0– 68
E 5357	43	E 5377	E 5387 Z	E 5377 G	E 5377 K	58		0– 130
E 5357 J	28	E 5377 J	E 5387 ZJ	E 5377 GJ	E 5377 KJ	38		0– 200
E 5358	22.5	E 5378	E 5388 Z	E 5378 G	E 5378 K	30		0– 250
E 5358 J	14	E 5378 J	E 5388 ZJ	E 5378 GJ	E 5378 KJ	19		0– 400



DC / AC Inverters, AC / AC Frequency Converters & Static Switches

- **Input voltage:** 10-800V DC or 115/ 230V AC, single phase, 47-400Hz or 200/ 400/ 480V AC, three phase, 47-400Hz
- **Output voltage:** 115/ 230 V AC, single phase or 200/ 400/ 480V AC, three phases
- **Output frequency:** 50/ 60/ 400/ 800Hz (crystal stabilized) or programmable within 40-400Hz or 400-800Hz
- **Output power:** 200VA - 45kVA

Features

- Sine Wave
- Continuous short circuit protection
- Thermal shutdown with auto-restart for 1-phase inverters >1.2kVA 3-phase inverters >3.6kVA
- Suitable for complex load
- Surge power capability
- Industrial grade components
- Compact and robust design
- **3-phase output:** Unsymmetrical load permissible, modular system with interchangeable inverters

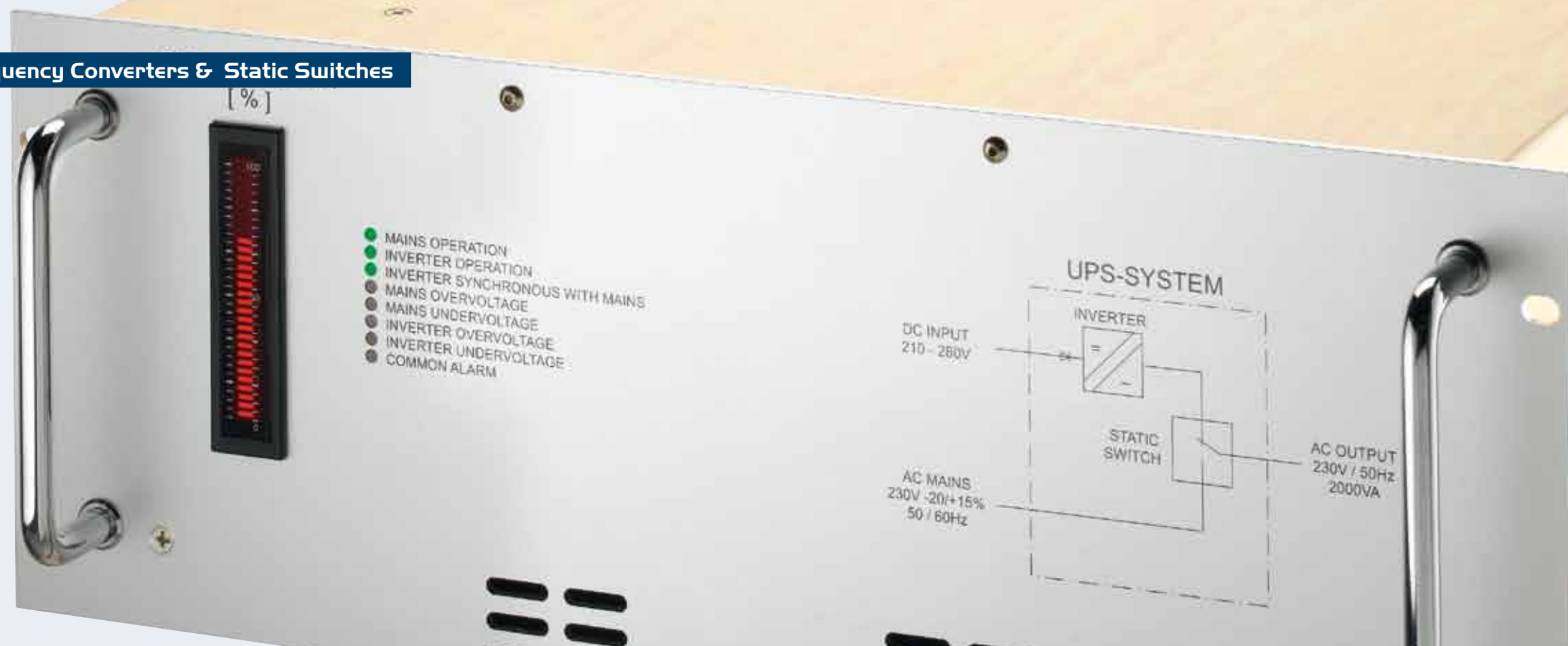

Specifications

Input

Voltage range	unit switches off at under- and overvoltage
No-load input power	10 – 30 W
Inrush current	for AC input and DC input >160V: limited by thermistor
Hold-up time	AC input: 10 ms typical Series CI: 20ms typical
Immunity	acc. to EN 61000-6-2

General

Efficiency	80 – 92 %		
Operating temperature	– 20 to + 75 °C optional: -40 to +75 °C		
Load derating	2.5%/°C above + 55 °C		
Storage temperature	-40 to + 85 °C		
Cooling	☼ = natural convection ☼ = incl. temperature controlled fans (details see page 131)		
Humidity	up to 95 % RH, non-condensing		
Safety / Construction	acc. to EN 60950-1 / EN 50178		
Protection category	IP20 acc. to EN 60529, NEMA or others upon request		
EMI	acc. to EN 61000-6-4, class A, optionally class B		
MTBF @40°C acc. to MIL -HDBK-217E (notice1)	series IT:	series CI:	series IV:
	120.000h	70.000h	50.000h

Output

Output voltages	115V AC	230V AC
	3x200VAC	3x400VAC 3x480VAC or any other
Output power	from 200 VA up to 45k VA	
Line regulation (±10%)	0.1 % for series CI, 2 % for series IT and IV 3 % for series IT and IV @ 400Hz	
Load regulation (10-90%)	1 % typical, 3 % max. (400 Hz: 3 % typical, 5 % max.)	
Turn-on rise time	soft-start, 100ms typical	
Waveform	sine wave or any wave shape programmable by external signal	
Frequency	40 – 800 Hz: adjustable or programmable or any fixed frequency (crystal stabilized)	
Distortion	3 % typical, 5 % @ 400 Hz, 7 % @ 40 – 400 Hz, 800Hz	
Overload protection (steady state)	current limited to approx. 1.05 x nominal current	
Surge power	2 x nominal power for 1 s	
Short circuit protection	electronically limited to 3 x nominal current, unit switches off after 1 s	
Crest factor	approx. 3	
Power factor	cos 0.7 inductive / capacitive	

Options (details see page 115)

Input

- Inrush current limiting for DC input
- Reverse polarity protection for DC input
- Autoranging for 115 / 230 VAC input
- Special circuit for 16.6Hz AC input

Output

- Remote on / off (inhibit)
- Static Switch (details see page 97)
- Parallel operation for redundancy or increased power: series IT5xxx

Signals

- via relay contacts
- Power ok (input)
- AC ok (output)

Monitoring

- of input / output voltage, current or frequency via
- analog signal
- interface card RS232 or CAN Bus (external)

Programming

- of output voltage, current or frequency via
- potentiometer
- analog signal
- interface card RS232 or CAN Bus (external)

Mechanics / environment:

- 19" sub-rack for eurocassette, refer to page 121
- Wall mount
- Increased mechanical strength
- Tropical protection
- Extended temperature range to –40 °C
- Temperature controlled fans for 19" units

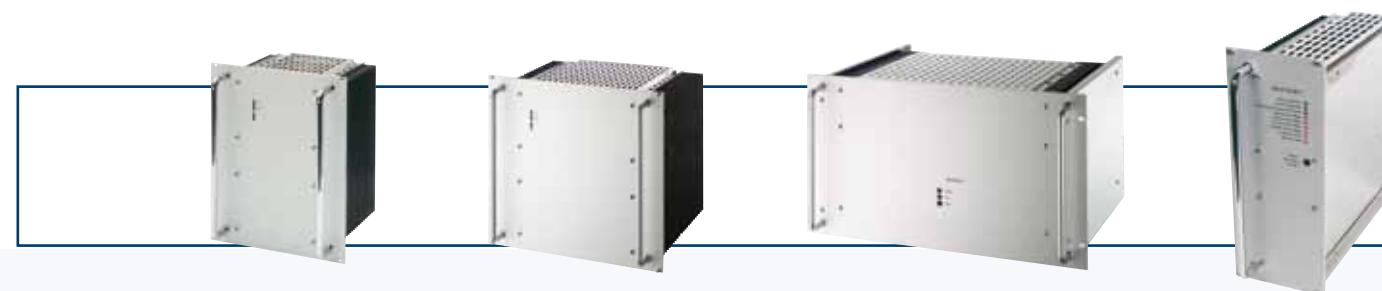

Series IT - Inverters with 1-phase output ▶ from 200 VA to 15 kVA **Page 89**

DC/AC Inverters

is a combination of a switch mode Inverter and a Transformer at the output. The transformer provides the isolation between input and output and transforms the voltage to the required level.

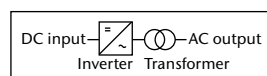

AC/AC Frequency Converters

is a combination of a switch mode Inverter with a rectifier at the input and a Transformer at the output. The transformer provides the isolation between input and output and transforms the voltage to the required level.

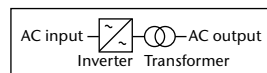

For lower input voltages the CI version is more compact than the IT version.

Series CI - Inverters with 1-phase output ▶ from 400 VA to 3.5 kVA **Page 91**

DC/AC Inverters

is a combination of a switch mode Converter and Inverter. The converter provides the isolation between input and output and transforms the voltage to the level needed by the inverter for supplying the specified AC output voltage.

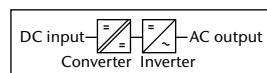

AC/AC Frequency Converters

is a combination of a switch mode Converter and Inverter. The converter provides the isolation between input and output and transforms the voltage to the level needed by the inverter for supplying the specified AC output voltage.

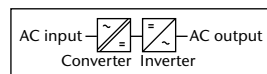

Series CV & IV - Inverters with 3-phase output ▶ from 600VA to 45 kVA **Page 93 a & b)**

DC/AC or AC/AC

is a combination of 3 individual switch mode inverters synchronized for a symmetrical 3-phase output. For series CV the converters provides the isolation between input and output; For series IV the transformers provide the isolation between input and output and transform the voltages to the required levels.

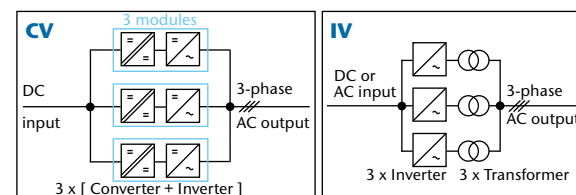

Series SS ▶ from 800 VA to 10 kVA **Page 97**

Static Switches

The Static Switch has two inputs for load supply, a priority and a non-priority input, and synchronizes the frequency of one supply to the other. Typically, but not exclusively, supplied by Mains & an Inverter, there are 3 modes of operation:

1. Service mode Mains - mains is selected as the load provider.
2. Service mode Inverter - inverter is selected as the load provider.
3. Automated function with priority selection.

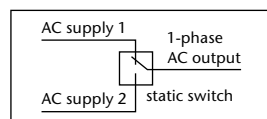

Series U ▶ from 1 to 2.5 kVA **Page 99**

UPS Systems with Static Switch

provides uninterrupted AC power to a critical load by connecting the load to AC supply 1 which can be the inverter output or to AC supply 2 which can be the mains. Series U does not include the batteries. The batteries can be specified and both, batteries and charger can be added to the system.

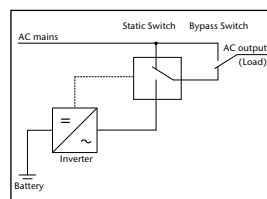

Connectors ▶ for Series CI, IT, IV & SS **Page 132**

Mechanics	Series CI	Series IT	Series IV	Series SS	Series U
Eurocassette	H15 & high current connector for I > 50 A	H15 and F24H7	--	H15 and F48	--
Wall mount or 19" unit	Terminals	Terminals	Terminals	Terminals	Terminals



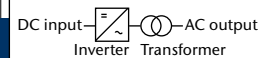

DC / AC Inverters with 1-phase output from 200VA to 15kVA

		Input VDC														Cooling	Output VAC
20-32 VDC	Output kVA	Size	40-64 VDC	50-80 VDC	Output kVA	Size	80-160 VDC	Output kVA	Size	160-320 VDC	340-400 VDC	340-640 ¹⁾ VDC	450-800 ¹⁾ VDC	Output kVA	Size		
IT 1626	0.2	A	IT 1636	IT 1646	0.4	A	IT 1656	0.5	A	IT 1676	IT 1686 Z				0.5	A	115
			IT 3636	IT 3646	0.5	B	IT 3656	1	B	IT 3676	IT 3686 Z	IT 3676 G			1	B	
			IT 4836	IT 4846	1.2	D	IT 4856	2	C	IT 4876	IT 4886 Z	IT 3876 G	IT 3876 K		1.6	C	
			IT 5636	IT 5646	2	E	IT 5656	3	D	IT 4876 G	IT 4876 K	IT 4876 G	IT 4876 K		2.5	D	
			IT 5736	IT 5746	3	E	IT 5756	5	E	IT 5676	IT 5686 Z	IT 5676 G	IT 5676 K		5	F+T1	
									F+T1	IT 5776	IT 5786 Z	IT 5776 G	IT 5776 K		8	F+T2	
IT 1628	0.2	A	IT 1638	IT 1648	0.4	A	IT 1658	0.5	A	IT 1678	IT 1688 Z				0.5	A	230
			IT 3638	IT 3648	0.5	B	IT 3658	1	B	IT 3678	IT 3688 Z	IT 3678 G			1	B	
			IT 4838	IT 4848	1.2	D	IT 4858	2	C	IT 3878	IT 3888 Z	IT 3878 G	IT 3878 K		1.6	C	
			IT 5638	IT 5648	2	E	IT 5658	3	D	IT 4878	IT 4888 Z	IT 4878 G	IT 4878 K		2.5	D	
			IT 5738	IT 5748	3	E	IT 5758	5	E	IT 5678	IT 5688 Z	IT 5678 G	IT 5678 K		5	F+T1	
									F+T1	IT 5778	IT 5788 Z	IT 5778 G	IT 5778 K		8	F+T2	

☐ = natural convection * = incl. temperature controlled fans ¹⁾ standard version: wall mount

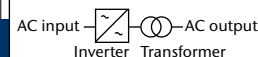

AC / AC Frequency Converters with 1-phase output from 500VA to 15kVA

Input VAC 1-Phase	Output kVA	Size	Input VAC				Output kVA	Size	Cooling	Output VAC
			1-Phase	3-Phase						
115 ±20%			230 ^{+15% -20%}	3x200 ^{+15% -20%}	3x400 ^{+15% -20%}	3x480 ^{+10% -15%}				
IT 1666	0.5	A	IT 1686	IT 1666 V	IT 3686 V		0.5	A	115	
IT 3666	1	B	IT 3686	IT 3666 V	IT 3886 V	IT 3896 V	1	B		
IT 3866	1.2	C	IT 3886	IT 3866 V	IT 4886 V	IT 4896 V	1.6	C		
IT 4866	2	D	IT 4886	IT 4866 V	IT 5686 V	IT 5696 V	2.5	D		
IT 5666	3	E	IT 5686	IT 5666 V	IT 5786 V	IT 5796 V	5	F+T1		
IT 5766	5	F+T1	IT 5786	IT 5766 V	IT 5886 V	IT 5896 V	8	F+T2		
IT 1668	0.5	A	IT 1688	IT 1668 V	IT 3688 V		0.5	A	230	
			IT 3688	IT 3668 V	IT 3888 V	IT 3898 V	1	B		
			IT 3888	IT 3868 V	IT 4888 V	IT 4898 V	1.6	C		
			IT 4888	IT 4868 V	IT 5688 V	IT 5698 V	2.5	D		
			IT 5688	IT 5668 V	IT 5788 V	IT 5798 V	5	F+T1		
			IT 5788	IT 5768 V	IT 5888 V	IT 5898 V	8	F+T2		

☐ = natural convection * = incl. temperature controlled fans

Frequency Designation

.1	40 - 400 Hz adjustable / programmable
.2	45 - 65 Hz adjustable / programmable
.3	any fixed frequency between 40 - 400 Hz
.4	400 Hz
.41	synchronized with 400 Hz mains
.5	50 Hz
.51	synchronized with 50 Hz mains
.6	60 Hz
.61	synchronized with 60 Hz mains
.7	50/60 Hz switchable
.8	800 Hz

Size A

Standard: Eurocassette / approx. 9 kg

Optional: Wall mount / approx. 11 kg

Size B

Standard: Eurocassette / approx. 11 - 13 kg

Optional: Wall mount / approx. 13 - 15 kg

Size C

Standard: Eurocassette / approx. 16 - 18 kg

Optional: Wall mount / approx. 19 - 21 kg

Size D

Standard: Eurocassette / approx. 18 - 24 kg

Optional: Wall mount / approx. 21 - 27 kg

Size E

Standard: 19" Plug-in module / approx. 46 - 50 kg

Optional: Wall mount / approx. 54 - 58 kg

Size F

Standard: 19" Plug-in module / approx. 32 kg

Optional: Wall mount / approx. 36 kg

Size L

Optional: 19", 3U Plug-in module

19", 3U high packages: available for series IT16xx up to IT36xx.

* = incl. temperature controlled fans

Size T1 - T4

Transformer	H	W	D	Weight in kg
T1	390	240	233	33
T2	450	280	253	50
T3	450	280	283	66
T4	500	320	280	110

Transformers refer to 50/60 Hz. Other frequencies or tropical insulation may change size and weight.

Standing version

Size T1

Transformer	H	W	D	Weight in kg
T1	335	230	210	33

Transformers refer to 50/60 Hz. Other frequencies or tropical insulation may change size and weight.

Wall mount version

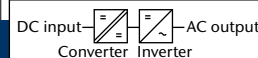

DC / AC Inverters with I-phase output from 400VA to 3.5kVA

Input VDC														Cooling	Output VAC	
10-16 VDC	Output kVA	Size	20-32 VDC	Output kVA	Size	40-64 VDC	50-80 VDC	80-160 VDC	160-320 VDC	320-380 VDC	320-640 ¹⁾ VDC	450-800 ¹⁾ VDC	Output kVA			Size
CI 1606	0.4	G	CI 1626	0.5	G	CI 1636	CI 1646	CI 1656	CI 1676	CI 1686 Z				0.6	G	115
			CI 3626	1	H	CI 3636	CI 3646	CI 3656	CI 3676	CI 3686 Z	CI 3676 G			1.2	H	
CI 4806	0.8	I	CI 4826	1.4	I	CI 4836	CI 4846	CI 4856	CI 4876	CI 4886 Z	CI 4876 G	CI 4876 K	1.8	I		
			CI 5626	2	K	CI 5636	CI 5646	CI 5656	CI 5676	CI 5686 Z	CI 5676 G	CI 5676 K	2.4	K	230	
CI 5706	2	K	CI 5726	3	K	CI 5736	CI 5746	CI 5756	CI 5776	CI 5786 Z	CI 5776 G	CI 5776 K	3.5	K		
CI 1608	0.4	G	CI 1628	0.5	G	CI 1638	CI 1648	CI 1658	CI 1678	CI 1688 Z			0.6	G	230	
			CI 3628	1	H	CI 3638	CI 3648	CI 3658	CI 3678	CI 3688 Z	CI 3678 G		1.2	H		
CI 4808	0.8	I	CI 4828	1.4	I	CI 4838	CI 4848	CI 4858	CI 4878	CI 4888 Z	CI 4878 G	CI 4878 K	1.8	I		
			CI 5628	2	K	CI 5638	CI 5648	CI 5658	CI 5678	CI 5688 Z	CI 5678 G	CI 5678 K	2.4	K	230	
CI 5708	2	K	CI 5728	3	K	CI 5738	CI 5748	CI 5758	CI 5778	CI 5788 Z	CI 5778 G	CI 5778 K	3.5	K		

☐ = natural convection ☀ = incl. temperature controlled fans ¹⁾ standard version: wall mount

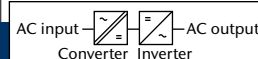

AC / AC Frequency Converters with I-phase output from 600VA to 3.5kVA

Input VAC 1-Phase			Input VAC 3-Phase			Output kVA	Size	Cooling	Output VAC
115 ±20%	230 ^{+15%} / _{-20%}	115 ^{±20%} / _{230 ^{+15%}/_{-20%}}	3x200 ^{+15%} / _{-20%}	3x400 ^{+15%} / _{-20%}	3x480 ^{+10%} / _{-15%}				
CI 1666	CI 1686	CI 1696	CI 1666 V		CI 1696 V	0.6	G	115	
CI 3666	CI 3686	CI 3696	CI 3666 V	CI 3686 V	CI 3696 V	1.2	H		
CI 4866	CI 4886	CI 4896	CI 4866 V	CI 4886 V	CI 4896 V	1.8	I		
CI 5666	CI 5686	CI 5696	CI 5666 V	CI 5686 V	CI 5696 V	2.4	K	230	
CI 5766	CI 5786		CI 5766 V	CI 5786 V	CI 5796 V	3.5	K		
CI 1668	CI 1688	CI 1698	CI 1668 V		CI 1698 V	0.6	G	230	
CI 3668	CI 3688	CI 3698	CI 3668 V	CI 3688 V	CI 3698 V	1.2	H		
CI 4868	CI 4888	CI 4898	CI 4868 V	CI 4888 V	CI 4898 V	1.8	I		
CI 5668	CI 5688	CI 5698	CI 5668 V	CI 5688 V	CI 5698 V	2.4	K	230	
CI 5768	CI 5788		CI 5768 V	CI 5788 V	CI 5798 V	3.5	K		

☐ = natural convection ☀ = incl. temperature controlled fans

Size G

Standard: Eurocassette / approx. 6 kg

Optional: Wall mount / approx. 8 kg

Size H

Standard: Eurocassette / approx. 10 kg

Optional: Wall mount / approx. 12 kg

Size I

Standard: Eurocassette / approx. 18 kg

Optional: Wall mount / approx. 21 kg

Size K

Standard: 19" Plug-in module / approx. 28-32 kg
*) less depth upon request

Optional: Wall mount / approx. 34-38 kg
**) applicable for CI 5706, 5708 5726 and 5728

Size M

Optional: 19" 2U Plug-in module

19", 2U high packages: available for series CI16xx.

☀ = incl. temperature controlled fans

Frequency Designation

.0	any external signal (control, ramp) → only for Series CI
.1	40 - 400 Hz adjustable / programmable
.2	45 - 65 Hz adjustable / programmable
.3	any fixed frequency between 40 - 400 Hz
.4	400 Hz
.41	synchronized with 400 Hz mains
.5	50 Hz
.51	synchronized with 50 Hz mains
.6	60 Hz
.61	synchronized with 60 Hz mains
.7	50/60 Hz switchable
.8	800 Hz

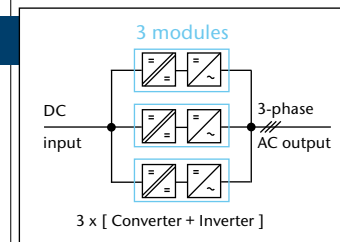

Series CV

Switch mode converter (with isolation) and inverter in three modules
Please note: additional rack or wall plate required

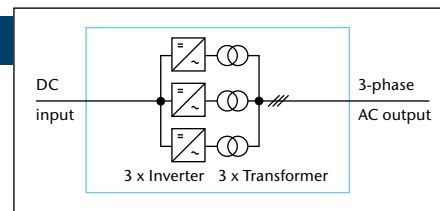

Series IV

Switch mode inverter with output transformer for isolation and voltage transformation

		Input VDC						Cooling	Output VAC line-to-line
10-16 VDC	Output kVA	20-32 VDC	Output kVA	40-64 VDC	50-80 VDC	Output kVA	Size		
CV 5806 ¹⁾	2.4	CV 5826 ¹⁾	0.6	IV 5536	IV 5546	1.2	A	3 x 200	
		CV 5626	1.5	IV 5636	IV 5646	1.5	B		
		CV 5726	3	CV 5736	CV 5746	1.8	M / N		
				IV 5836	IV 5846	3.6	E+T1		
				CV 5836	CV 5846	3.6	P		
				IV 6236	IV 6246	6	G+T2		
CV 6406	6	CV 6226	6	CV 6236	CV 6246	7.2	Q	3 x 400	
		CV 6426	9	IV 6436	IV 6446	9	G+T3		
				CV 6436	CV 6446	10.5	Q		
				IV 5528	IV 5538	1.2	A		
CV 5808 ¹⁾	2.4	CV 5828 ¹⁾	0.6	IV 5638	IV 5648	1.5	B	3 x 400	
		CV 5628	1.5	CV 5638	CV 5648	1.8	M / N		
		CV 5728	3	CV 5738	CV 5748	3.6	O		
				IV 5838	IV 5848	3.6	E+T1		
				CV 5838	CV 5848	5.4	P		
				IV 6238	IV 6248	6	G+T2		
CV 6408	6	CV 6228	6	CV 6238	CV 6248	7.2	Q	3 x 480	
		CV 6428	9	IV 6438	IV 6448	9	G+T3		
				IV 6438	IV 6448	9	G+T3		
				IV 5529	IV 5539	1.2	A		
CV 6408	6	CV 5639	1.5	IV 5649	IV 5649	1.5	B	3 x 480	
		IV 5839	3.6	IV 5849	IV 5849	3.6	E+T1		
		IV 6239	6	IV 6249	IV 6249	6	G+T2		
		IV 6439	9	IV 6449	IV 6449	9	G+T3		
				IV 5539	IV 5549	1.2	A		
				IV 5639	IV 5649	1.5	B		

☐ = natural convection ☀ = incl. temperature controlled fans

¹⁾ external fan recommended

Frequency Designation

- .1 40 - 400 Hz adjustable / programmable
- .2 45 - 65 Hz adjustable / programmable
- .3 any fixed frequency between 40 - 400 Hz
- .4 400 Hz (module size of series IV may be smaller)
- .41 synchronized with 400 Hz mains
- .5 50 Hz
- .51 synchronized with 50 Hz mains
- .6 60 Hz
- .61 synchronized with 60 Hz mains
- .7 50/60 Hz switchable
- .8 800 Hz (module size of series IV may change)

Size A

Standard
19" sub-rack / approx. 24 / 27 kg¹⁾

Optional
Wall mount / approx. 28 / 31 kg¹⁾

Size B

Standard
19" sub-rack / approx. 33 kg¹⁾

Optional
Wall mount / approx. 38 kg¹⁾

Size E

Standard
19" sub-rack / approx. 35 kg¹⁾

Optional
Wall mount / approx. 65 kg¹⁾

Size G

Attention: 3 modules are required

Standard
19" Plug-in module / approx. 32kg¹⁾ ☀

Optional
Wall mount / approx. 36kg¹⁾ ☀

Size T1 - T3

Transformer	Ø in mm	H in mm	approx. Weight in kg	Power in kVA
T1	190	75	8.6	1.4
T2	205	85	12	2
T3	243	85	15	3

Transformers refer to 50/60 Hz at the output. Other frequencies or tropical insulation may change size and weight.
Attention: For 3-phase system 3 transformers are required.

Size M

Attention: 3 modules are required

Optional
19", 2U Plug-in module ☀

Size N

Attention: 3 modules are required

Standard
Eurocassette / approx. 6 kg

Optional
Wall mount / approx. 8 kg

Size O

Attention: 3 modules are required

Standard
Eurocassette / approx. 10 kg

Optional
Wall mount / approx. 12 kg

Size P

Attention: 3 modules are required

Standard
Eurocassette / approx. 18 kg

Optional
Wall mount / approx. 21 kg

Size Q

Attention: 3 modules are required

Standard less depth upon request
19" Plug-in module / approx. 28-32 kg ☀

Optional
Wall mount / approx. 34-38 kg ☀

¹⁾ transformers internal ¹⁾ transformers external ☀ = incl. temperature controlled fans

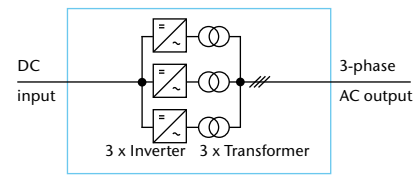

Series IV

Switch mode inverters with output transformers for isolation and voltage transformation

Input VDC										Cooling	Output VAC line-to-line
80-160 VDC	Output kVA	Size	160-320 VDC	340-400 VDC	340-640 ¹⁾ VDC	450-800 ¹⁾ VDC	Output kVA	Size			
IV 5556	1.5	A	IV 5576	IV 5586 Z			1.8	A	3 x 200		
IV 5656	3	C	IV 5676	IV 5686 Z	IV 5676 G		3.6	C			
			IV 5776	IV 5786 Z			5.4	D+T2			
					IV 5776 G	IV 5776 K	5.4	D+T2			
IV 5856	6	E+T2	IV 5876	IV 5886 Z	IV 5876 G	IV 5876 K	7.5	F+T3			
			IV 5876 F ²⁾	IV 5886 ZF	IV 5876 GF ²⁾	IV 5876 KF ²⁾	10	F+T4			
IV 6256	9	G+T3	IV 6276	IV 6286 Z	IV 6276 G	IV 6276 K	15	G+T5			
IV 6456	15	G+T5	IV 6476	IV 6486 Z	IV 6476 G	IV 6476 K	24	G+T6			
			IV 6676	IV 6686 Z	IV 6676 G	IV 6676 K	30	G+T7			
			IV 6876	IV 6886 Z	IV 6876 G	IV 6876 K	45	G+T8			
IV 5558	1.5	A	IV 5578	IV 5588 Z			1.8	A		3 x 400	
IV 5658	3	C	IV 5678	IV 5688 Z	IV 5678 G		3.6	C			
			IV 5778	IV 5788 Z			5.4	D+T2			
					IV 5778 G	IV 5778 K	5.4	D+T2			
IV 5858	6	E+T2	IV 5878	IV 5888 Z	IV 5878 G	IV 5878 K	7.5	F+T3			
			IV 5878 F ²⁾	IV 5888 ZF	IV 5878 GF ²⁾	IV 5878 KF ²⁾	10	F+T4			
IV 6258	9	G+T3	IV 6278	IV 6288 Z	IV 6278 G	IV 6278 K	15	G+T5			
IV 6458	15	G+T5	IV 6478	IV 6488 Z	IV 6478 G	IV 6478 K	24	G+T6			
			IV 6678	IV 6688 Z	IV 6678 G	IV 6678 K	30	G+T7			
			IV 6878	IV 6888 Z	IV 6878 G	IV 6878 K	45	G+T8			
IV 5559	1.5	A	IV 5579	IV 5589 Z			1.8	A	3 x 480		
IV 5659	3	C	IV 5679	IV 5689 Z	IV 5679 G		3.6	C			
			IV 5779	IV 5789 Z			5.4	D+T2			
					IV 5779 G	IV 5779 K	5.4	D+T2			
IV 5859	6	E+T2	IV 5879	IV 5889 Z	IV 5879 G	IV 5879 K	7.5	F+T3			
			IV 5879 F ²⁾	IV 5889 ZF	IV 5879 GF ²⁾	IV 5879 KF ²⁾	10	F+T4			
IV 6259	9	G+T3	IV 6279	IV 6289 Z	IV 6279 G	IV 6279 K	15	G+T5			
IV 6459	15	G+T5	IV 6479	IV 6489 Z	IV 6479 G	IV 6479 K	24	G+T6			
			IV 6679	IV 6689 Z	IV 6679 G	IV 6679 K	30	G+T7			
			IV 6879	IV 6889 Z	IV 6879 G	IV 6879 K	45	G+T8			

☐ = natural convection ☀ = incl. temperature controlled fans

¹⁾ standard version: wall mount

²⁾ input voltage range to be narrowed

Frequency Designation

Frequency Designation

.1	40 - 400 Hz adjustable / programmable
.2	45 - 65 Hz adjustable / programmable
.3	any fixed frequency between 40 - 400 Hz
.4	400 Hz (module size of series IV may be smaller)
.41	synchronized with 400 Hz mains
.5	50 Hz
.51	synchronized with 50 Hz mains
.6	60 Hz
.61	synchronized with 60 Hz mains
.7	50/60 Hz switchable
.8	800 Hz (module size may change)

Size A

Standard: 19" sub-rack / approx. 30 kg¹⁾

Optional: with wall plate / approx. 34 kg¹⁾

Size C

Standard: 19" sub-rack / approx. 40 kg¹⁾

Optional: with wall plate / approx. 45 kg¹⁾

Size D

Standard: 19" sub-rack / approx. 24 kg¹⁾

Optional: with wall plate / approx. 65 kg¹⁾

Size E

Standard: 19" sub-rack / approx. 35 kg¹⁾

Optional: with wall plate / approx. 80 kg¹⁾

Size F

Standard: 19" sub-rack / approx. 37 kg¹⁾

Optional: with wall plate / 90 / 115 kg¹⁾

Size G

Standard: 19" Plug-in module / approx. 30 kg¹⁾

Optional: with wall plate / approx. 36 kg¹⁾

Attention: 3 modules are required

Size T1 - T3

Transformer	Ø in mm	H in mm	approx. Weight in kg	Power in kVA
T1	190	75	8.6	1.4
T2	205	85	12	2
T3	243	85	15	3

Transformers refer to 50/60 Hz at the output. Other frequencies or tropical insulation may change size and weight. Attention: For 3-phase system 3 transformers are required.

Size T4

approx. 23 kg / 3.4 kVA

Transformer refers to 50/60 Hz at the output. Other frequencies or tropical insulation may change size and weight. Attention: For 3-phase system 3 transformers are required.

Size T5 - T8

Transformer	H in mm	W in mm	D in mm	approx. Weight in kg	Power in kVA
T5	390	240	233	33	5
T6	450	280	253	50	8
T7	450	280	283	66	12
T8	500	320	280	110	15

Transformers refer to 50/60 Hz at the output. Other frequencies or tropical insulation may change size and weight. Attention: For 3-phase system 3 transformers are required.

Size T5

Transformer	H in mm	W in mm	D in mm	approx. Weight in kg	Power in kVA
T5	335	230	210	33	5

Transformers refer to 50/60 Hz at the output. Other frequencies or tropical insulation may change size and weight. Attention: For 3-phase system 3 transformers are required.

¹⁾ transformers internal

¹⁾ transformers external

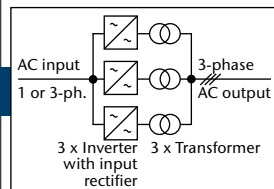

AC / AC Inverters with 3-phase output from 1.5kVA to 45kVA

Input VAC 1-Phase	Output kVA	Size	Input VAC 1-Phase	Input VAC 3-Phase			Output kVA	Size	Cooling	Output VAC line-to-line
				230 ^{+15%} _{-20%}	3x200 ^{+15%} _{-20%}	3x400 ^{+15%} _{-20%}				
IV 5566	1.5	A	IV 5586	IV 5566 V			1.8	A	3 x 200	
IV 5666	3	C	IV 5686	IV 5666 V	IV 5686 V		3.6	C		
IV 5766	3.6	D+T1	IV 5786	IV 5766 V	IV 5786 V	IV 5796 V	5.4	D+T2		
IV 5866	6	E+T2	IV 5886	IV 5866 V	IV 5886 V	IV 5896 V	7.5	E+T3		
IV 6266	9	G+T3	IV 6286	IV 6266 V	IV 6286 V	IV 6296 V	15	G+T5	3 x 400	
IV 6466	15	G+T5	IV 6486	IV 6466 V	IV 6486 V	IV 6496 V	24	G+T6		
					IV 6686 V	IV 6696 V	36	G+T7		
					IV 6886 V	IV 6896 V	45	G+T8		
IV 5568	1.5	A	IV 5588	IV 5568 V			1.8	A	3 x 480	
IV 5668	3	C	IV 5688	IV 5668 V	IV 5688 V		3.6	C		
IV 5768	3.6	D+T1	IV 5788	IV 5768 V	IV 5788 V	IV 5798 V	5.4	D+T2		
IV 5868	6	E+T2	IV 5888	IV 5868 V	IV 5888 V	IV 5898 V	7.5	E+T3		
IV 6268	9	G+T3	IV 6288	IV 6268 V	IV 6288 V	IV 6298 V	15	G+T5	3 x 480	
IV 6468	15	G+T5	IV 6488	IV 6468 V	IV 6488 V	IV 6498 V	24	G+T6		
					IV 6688 V	IV 6698 V	36	G+T7		
					IV 6888 V	IV 6898 V	45	G+T8		
IV 5569	1.5	A	IV 5589	IV 5569 V			1.8	A	3 x 480	
IV 5669	3	C	IV 5689	IV 5669 V	IV 5689 V		3.6	C		
IV 5769	3.6	D+T1	IV 5789	IV 5769 V	IV 5789 V	IV 5799 V	5.4	D+T2		
IV 5869	6	E+T2	IV 5889	IV 5869 V	IV 5889 V	IV 5899 V	7.5	E+T3		
IV 6269	9	G+T3	IV 6289	IV 6269 V	IV 6289 V	IV 6299 V	15	G+T5	3 x 480	
IV 6469	15	G+T5	IV 6489	IV 6469 V	IV 6489 V	IV 6499 V	24	G+T6		
					IV 6689 V	IV 6699 V	36	G+T7		
					IV 6889 V	IV 6899 V	45	G+T8		

☐ = natural convection * = incl. temperature controlled fans

Standard
19" sub-rack / approx. 27 kg¹⁾

Optional
with wall plate / approx. 31 kg¹⁾

Standard
19" sub-rack / approx. 40 kg¹⁾

Optional
with wall plate / approx. 45 kg¹⁾

Standard
19" sub-rack / approx. 24 kg²⁾

Optional
with wall plate / 55/65 kg¹⁾

Standard
19" sub-rack / approx. 27 kg²⁾

Optional
with wall plate / approx. 70/80 kg¹⁾

Standard
19" sub-rack / approx. 28 kg²⁾

Optional
with wall plate / approx. 104 kg¹⁾

Standard
19" Plug-in module / approx. 32 kg

Optional
with wall plate / approx. 36 kg

Attention:
For 3-phase system
3 modules are required.

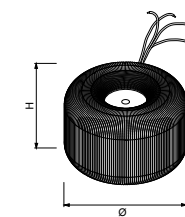

Trans- former	Ø in mm	H in mm	Weight in kg	Power in kVA
T1	190	75	8.6	1.4
T2	205	85	12	2
T3	243	85	15	3

Transformers refer to 50/60 Hz at the output. Other frequencies or tropical insulation may change size and weight.
Attention: For 3-phase system 3 transformers are required.

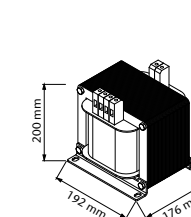

Size T4
Transformer refers to 50/60 Hz at the output. Other frequencies or tropical insulation may change size and weight.
Attention: For 3-phase system 3 transformers are required.

approx. 23 kg / 3.4 kVA

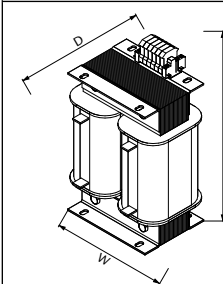

Trans- former	H in mm	W in mm	D in mm	Weight in kg	Power in kVA
T5	390	240	233	33	5
T6	450	280	253	50	8
T7	450	280	283	66	12
T8	500	320	280	110	15

Transformers refer to 50/60 Hz at the output. Other frequencies or tropical insulation may change size and weight.
Attention: For 3-phase system 3 transformers are required.

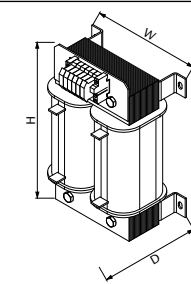

Trans- former	H in mm	W in mm	D in mm	Weight in kg	Power in kVA
T5	335	230	210	33	5

Transformers refer to 50/60 Hz at the output. Other frequencies or tropical insulation may change size and weight.
Attention: For 3-phase system 3 transformers are required.

Wall mount version

Frequency Designation

.1	40 - 400 Hz adjustable / programmable
.2	45 - 65 Hz adjustable / programmable
.3	any fixed frequency between 40 - 400 Hz
.4	400 Hz
.41	synchronized with 400 Hz mains
.5	50 Hz
.51	synchronized with 50 Hz mains
.6	60 Hz
.61	synchronized with 60 Hz mains
.7	50/60 Hz switchable
.8	800 Hz

¹⁾ transformers internal ²⁾ transformers external

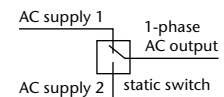

Static Switches with 1-phase output from 0.8 to 10kVA

Model	Output Power [kVA]	Cooling	Input / Output [V]
SS 1506	0.8	[Natural convection symbol]	115
SS 3506	1.6		
SS 3516	3		
SS 3526	5		
SS 3536	10		
SS 1508	0.8	[Natural convection symbol]	230
SS 3508	1.6		
SS 3518	3.2		
SS 3528	5		
SS 3538	10		

Frequency Designation	
.4	400 Hz
.5	50 Hz
.6	60 Hz
.8	800Hz

[Natural convection symbol] = natural convection

Series specific information

Function

The Static Switch has two inputs for load supply, a priority and a non-priority input, and synchronizes the frequency of one supply to the other. Typically, but not exclusively, supplied by Mains and an Inverter, there are 3 modes of operation:

1. Service mode Mains - mains is selected as the load provider.
2. Service mode Inverter - inverter is selected as the load provider.
3. Automated function with priority selection.

In the automated function the supply of the priority input is connected to the load. If the static switch detects deviation from tolerance through monitoring, it will transfer the load to the non-priority input. When the supply of the priority input has returned to be within parameters of voltage and frequency, the static switch reverses this selection.

For adapting the static switch to different requirements, the priority for mains or inverter operation can be selected externally via an opto-coupler. The static switch can also be inhibited via another opto-coupler for disconnecting the load. LEDs and potential-free relay contacts indicate the mode of operation and / or the status of alarms.

Indication of operation mode

	Green LED	Red LED	potential free contacts *)
Mains operation	■		■
Inverter operation	■		■
Inverter synchronous with mains	■		■
Mains over voltage		■	■
Mains under voltage		■	■
Inverter over voltage		■	■
Inverter under voltage		■	■
Common alarm		■	■
Service mode		■	

*) U_{max} = 250 VAC, I_{max} = 3 A

Input / Output

Surge current	5 x I _{nom} for 1 s
Overload protection	For models with I _{nom} ≤ 15 A: short circuit protected: unit switches off at output current above 15 A; For models with I _{nom} > 15 A: an external fuse with slow characteristic is required
Inhibit (remote on / off)	logic low = 0 – 5 V; logic high = 12 – 30 V via opto-coupler
Priority selection	logic low = 0 – 5 V; logic high = 12 – 30 V via opto-coupler
Transfer trigger	0.8 x U _{nom} < voltage < 1.15 x U _{nom}
Transfer time	
- mains to inverter (mains priority) or inverter to mains (inverter priority)	For models with I _{nom} ≤ 15 A: ≤ ½ period, typically ¼ period (including failure detection time) For models with I _{nom} > 15 A: one period, typically ½ period (including failure detection time)
- return to mains (mains priority) or return to inverter (inverter priority)	For models with I _{nom} ≤ 15 A: practically no interruption For models with I _{nom} > 15 A: typically ½ period

Options

Mechanics / environment	<ul style="list-style-type: none"> ■ 19" sub-rack for eurocassette, refer to page 121 ■ Wall mount ■ Increased mechanical strength ■ Tropical protection ■ Extended temperature range to -40 °C
-------------------------	--

6U



series SS 15xx

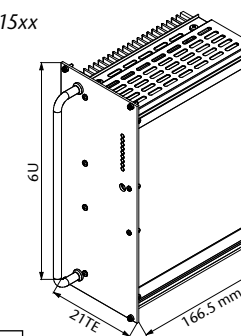

Standard

Eurocassette (pluggable module for 19" sub-rack) approx. 3.3 kg

series SS 15xx

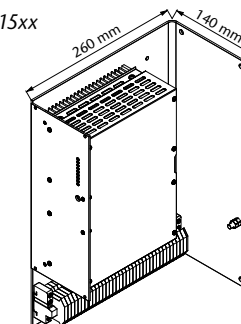

Optional

Wall mount approx. 6.3 kg

series SS 35xx

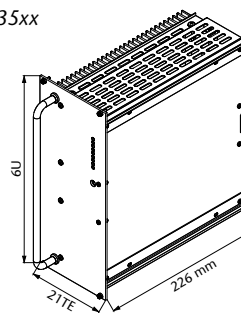

Standard

Eurocassette (pluggable module for 19" sub-rack) approx. 5.0 kg

series SS 35xx

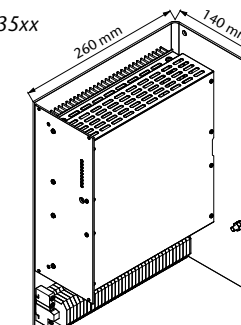

Optional

Wall mount approx. 8.0 kg

UPS with 1-phase output from 1 to 2.5kVA

Input VDC		Output kVA	Input VDC		Output kVA	Cooling	Input / Output VAC
40-64 VDC	50-80 VDC		80-160 VDC	160-320 VDC			
U 5436	U 5446	1.2	U 5256	1	U 5276	1	115
			U 5356	1.2	U 5376	1.6	
			U 5456	2	U 5476	2.5	
U 5438	U 5448	1.2	U 5258	1	U 5278	1	230
			U 5358	1.2	U 5378	1.6	
			U 5458	2	U 5478	2.5	

Frequency Designation	
.4	400 Hz
.5	50 Hz
.6	60 Hz

☼ = incl. temperature controlled fans

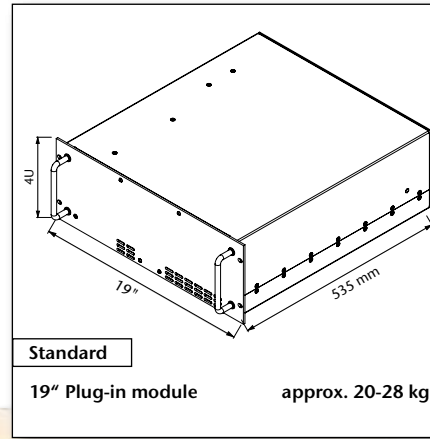

Series specific information

Function

The UPS provides uninterrupted power to a critical load, being supplied either by mains or by batteries via the internal inverter.

In the automated function the supply of the priority input (mains) is connected to the load. If the internal static switch detects deviation from tolerance, it will transfer the load to the non-priority input (inverter). When the supply of the priority input has returned to be within parameters of voltage and frequency, the static switch reverses this selection.

For adapting the UPS to different requirements, the priority for mains or inverter operation can be selected externally via switch on the rear side of the UPS. The UPS can also be inhibited either via opto-coupler or via external relay contact for disconnecting the load. LEDs indicate the mode of operation and / or the status of alarms. A potential-free relay contact is given for common alarm.

Optionally, a manual bypass switch can be provided for connecting the load directly to the mains while disconnecting the UPS or the batteries in case of maintenance. For maximum flexibility the batteries (external) can be specified according to the requirements on site and a suitable battery charger (external) can be chosen from the Schaefer product range.

Input / Output

Transfer time	
- mains to inverter (mains priority) or inverter to mains (inverter priority)	≤ ½ period, typically ¼ period (including failure detection time)
- return to mains (mains priority) or return to inverter (inverter priority)	practically no interruption
Transfer trigger	0.8 x U _{nom} < voltage < 1.15 x U _{nom}

Indication of operation mode

	Green LED	Red LED
Mains operation	■	
Inverter operation	■	
Inverter synchronous with mains	■	
Mains over voltage		■
Mains under voltage		■
Inverter over voltage		■
Inverter under voltage		■
Common alarm		■
incl. potential free contact*)		■

*) U_{max} = 250 VAC, I_{max} = 3 A

UPS System

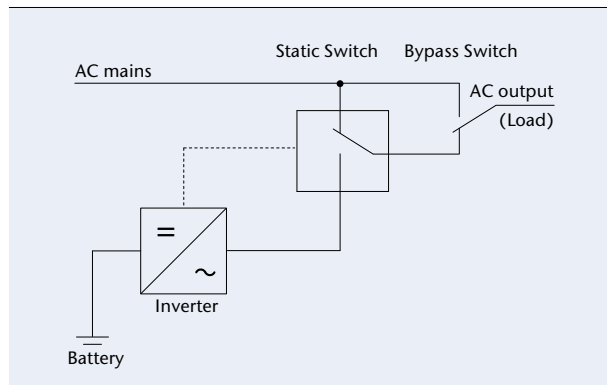

4U



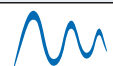

Power Balance Series

Features

- Modular system 60 A to 300 A extendable
- Harmonic compensation for 3-wire and 4-wire technology
- Up to 50th harmonic each individually selectable
- Ultrafast reactive power compensation
- Flicker compensation
- Load balancing between phases and unload neutral wire
- Grid resonance detection
- Ethernet and Ethercat system for interconnection
- Subsystems Display control unit, Active sensor unit, ModBus, PQ Analyzer ...



Specifications

Input & Output Parameters

Connectivity	3-wire: 3 phase 4-wire: 3 phase + neutral lead
Phase compensation current	60A 120A 180A 240A 300A
Neutral lead compensation current	180A 360A 540A 720A 900A
Input voltage	3-wire: 200 V - 480 V ± 10% 4-wire: 200 V - 400 V ± 10%
Frequency	50/60 Hz ± 3 Hz
Reaction time	21µs (immediate load change reaction)
Steady state response time	< 300µs (steady state response time to full steady state compensation)
Switching frequency	24 kHz
Control frequency	48 kHz
Digital control algorithm	<ul style="list-style-type: none"> ▪ Selective Direct Control algorithm ▪ Compensation up to 49th harmonic ▪ Individually selectable degree of compensation
Control functions	<ul style="list-style-type: none"> ▪ Harmonic compensation ▪ Reactive power compensation, adjustable power factor ▪ Reactive power injection (overcompensation) ▪ Load balancing

Power factor correction	Fully inductive and reactive current compensation from 0 to 100%
Overload current	150A 300A 450A 600A 750A @cf2.5@cf2.5@cf2.5@cf2.5@cf2.5
Current transformer	Source or Load side selectable, Primary current range 100 A – 10000 A, secondary current 1 A
Maximum power losses (W)	530 1100 1700 2000 2800
Weight single unit	60 kg
Weight including cabinet	90kg 150kg 210kg 270kg 330kg
Dimensions single unit	19" x 678 x 5U (W x D x H)
Dimensions including cabinet (mm)	570 x 815 x 808 570 x 815 x 1035 570 x 815 x 1260 570 x 815 x 1485 570 x 815 x 1710
Air flow rate	470 cfm 940 cfm 1410 cfm 1880 cfm 2350 cfm
Interface	Ethercat 100 Mbit/s, USB, Active sensor bus, Display bus
Ambient temperature	-10°C to +40°C full performance, up to +55°C derating 2% / K
Cooling	☼ = incl. temperature controlled fans
Humidity	95% non condensing

Options

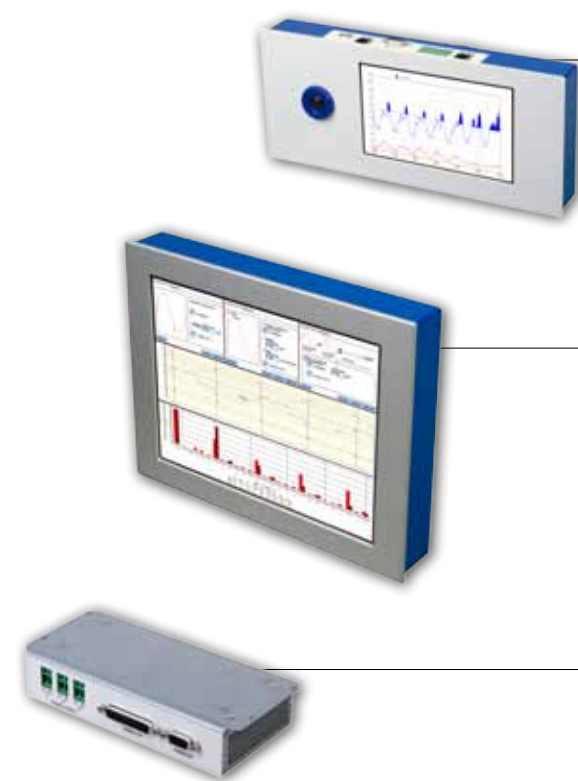

TFT 07	7" TFT control unit
	<ul style="list-style-type: none"> ▪ Input: 5 key navigation ▪ Operating system: embedded Linux ▪ Communication: Ethercat Master, Ethernet TCP/IP ▪ Interface: USB, Digital I/O, Display bus ▪ Dimensions (W x D x H): 308 x 45 x 135 mm ▪ Basic functionality: parameter setting, status indication, alarming, monitoring, event logging

TFT 12	12.1" TFT control unit
	<ul style="list-style-type: none"> ▪ Input: touchscreen ▪ Operating system: embedded Linux ▪ Communication: Ethercat Master, Ethernet TCP/IP ▪ Interface: USB, Digital I/O, Display bus ▪ Dimensions (W x D x H): 308 x 50 x 240 mm ▪ Basic functionality: parameter setting, status indication alarming, monitoring, event logging ▪ Extended functionality: power quality analyzer

SU	Active sensor unit
	<ul style="list-style-type: none"> ▪ Interface: Active sensor bus ▪ Dimensions (W x D x H): 186 x 90 x 35 mm ▪ Basic functionality: Source or Load side selectable, primary current range 100 A – 10000 A, secondary current 1A



Modular System



PB 10060	60 Amps Module
	consisting of <ul style="list-style-type: none"> one module 1 sensor unit 1 display
PB 10120	120 Amps Module
	consisting of <ul style="list-style-type: none"> two modules 1 sensor unit 1 display
PB 10180	180 Amps Module
	consisting of <ul style="list-style-type: none"> three modules 1 sensor unit 1 display
PB 10240	240 Amps Module
	consisting of <ul style="list-style-type: none"> four modules 1 sensor unit 1 display
PB 10300	300 Amps Module
	consisting of <ul style="list-style-type: none"> five modules 1 sensor unit 1 display

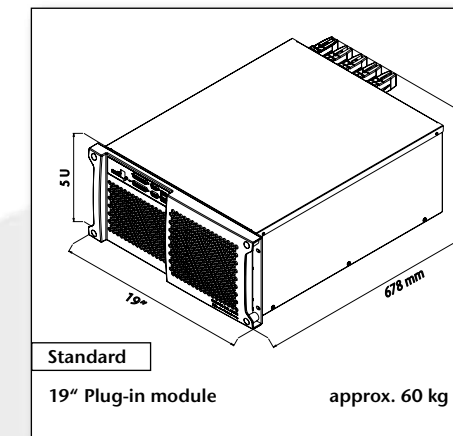

5U

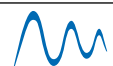
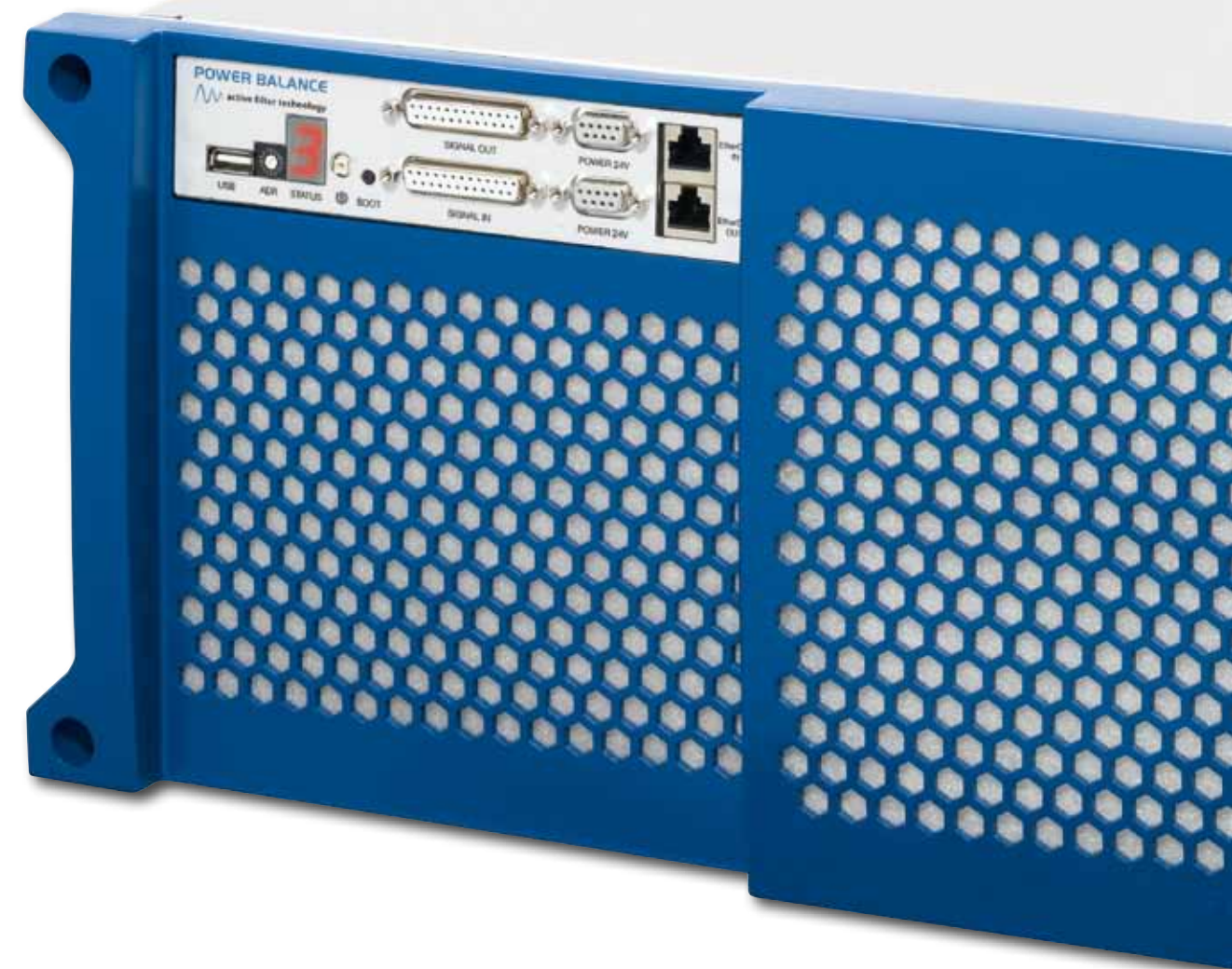

General Information

The PB-SERIES is an active harmonic filter system for tower buildings as well as automation, windturbine and various other industrial applications eliminating harmonic oscillations and consequently costs for reactive energy. The filter monitors the current signal & compen-

sates for the unwanted elements of the measured current. Thus, the filter ensures a harmonic suppression independently of the number of loads. Furthermore the filter corrects the power factor, improving the systems' efficiency while reducing harmonic pollution.

PB Active Harmonic Filter

Without POWER BALANCE:
Harmonic disturbances caused by e.g. non-linear loads.

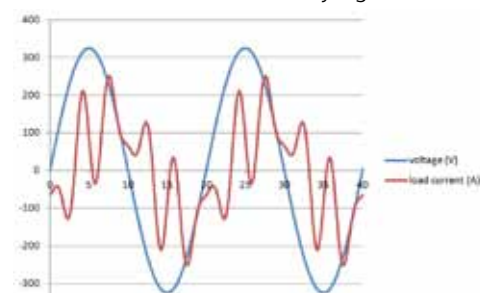

With POWER BALANCE:
Reactive power & harmonic oscillations are actively compensated.

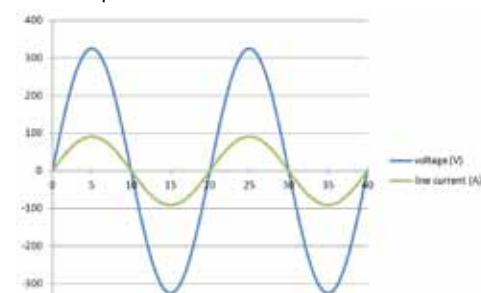



AC / DC Power Supplies & Battery Chargers

- **AC input voltage:**
115 / 230V AC, single phase, 50 / 60Hz
or 200/ 400/ 480/ 690V AC, 3-phase, 50 / 60Hz
- **Output voltage:** 12 / 24 / 48 / 60 / 72 /
110 / 220 / 360V
- **Output current:** up to 3250A
- **Output power:** 500W - 500kW

Features

- Robust design
- High reliable
- 6-pulse performance
- Optional: 10% input current distortion for 12-pulse charger
- Turn Key solution
- Constant current & voltage operation
- Industrial grade components
- High level of humidity protection
- Concise & clear indication panel



Specifications

Input

Voltage range	nominal voltage $\pm 10\%$ (other voltage upon request)
Frequency	50 or 60Hz $\pm 5\%$
Protection	by fuse

General

Efficiency	80 – 90%
- Series QE	82– 92% for models <48V DC
- Series QD	85– 95% for models $\geq 48V$ DC
Operating temperature	-10 to +40°C, optional up to +65°C
Humidity	up to 95 % RH, non-condensing
Altitude	up to 1000 m asl
Cooling	natural convection or internal fans
Audible noise	50-70dB (A) depending on power
Safety / Construction	acc. to EN 60950-1 / EN 50178
EMI	acc. to EN 61000-6-4, class A
Enclosure	
- Protection category	IP20 acc. to EN 60529, optional up to IP55
- Color	RAL7035, others upon request
Transformer	acc. to IEC 76 / IEC14 / EN 60591 / DIN VDE 0532

Output

Voltage	adjustable from 90 – 120% of U_{nom} (other voltage upon request)
Line regulation ($\pm 10\%$)	$\pm 0.5\%$
Load regulation (10-90%)	$\pm 1\%$
Dynamic load (10-90-10%)	$\pm 10\%$ typical
Ripple	$\leq 5\%$ rms without battery, optional: < 2% rms or 2mV frequency weighted
Current	electronic current limitation adjustable from 60 – 105% of I_{nom}
Overload protection	short circuit protected by fuse and electronic current limitation
Charging characteristic	IU acc. to DIN 41773 for Pb batteries DIN 41774 for NiCd batteries
Charging voltage	
- float	2.23 – 2.27V / cell for Pb batteries / 1.4V / cell for NiCd batteries
- equalize	2.35 – 2.4V / cell for Pb batteries / 1.55V / cell for NiCd batteries
- boost (manual activated)	2.7V / cell for Pb batteries / 1.7V 7 cell for NiCd batteries

Options

Input

- MCB, MCCB or isolator
- inrush current limiting
- 690V AC input

Output

- parallel or redundant operation
- 12-pulse performance
- filtering up to 0.1% pp (corresponding to 0.035% rms) or 2mV frequency weighted
- voltage stabilization

Control (details see page 123)

- IU characteristic acc. to DIN 41773 and 41774
- manual selection of charging characteristic (float / equalize / boost)
 - automatic selection of charging characteristic with timer
 - temperature compensated charging voltage

Battery

- MCB, MCCB or isolator
- deep discharge protection

Monitoring (details see page 123)

- analogue or micro-processor-controlled
- input/ output voltage
 - battery circuit
 - ground insulation failure
 - over temperature

Interface Card

- CAN Bus
- MOD Bus

Mechanics / environment:

- enclosures, IP20 up to IP55, for charger and / or batteries
- analogue or digital meters
- operating temperature up to +65°C
- tropical protection
- earthquake-proof
- vermin-proof

Converters / Inverters

- switchmode DC / DC converters from 100W to 40kW
- switchmode DC / AC inverters, frequency converters and static switches from 200 VA to 45k VA

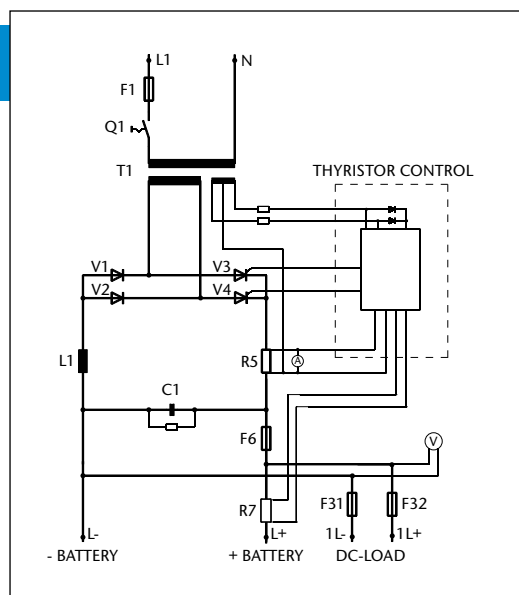

Model designation (example): QE 24 / 20

single phase input
 nominal output voltage [V]
 max. output current [A]

QE - Series

1-phase thyristor-controlled rectifiers, 500W-5kW						
nominal output voltage						
12V	24V	48V	60V	110V	220V	360V
max. output current						
from 0 to 130A						

enclosure size ¹⁾	nominal output voltage						approx. line current ²⁾ [A]	approx. weight ³⁾ [kg]
	12 V	24 V	48 V	60 V	110 V	220 V		
R3	30	20	10	8	5	2.5	4	28
	36	25	12.5	10	6	3	5	31
R4	50	32	16	14	8	4	6.5	40
	60	40	20	18	10	5	8	46
R5	80	55	30	25	14	7	11	60
	110	75	40	35	18	9	15	73
R5+	—	100	55	45	25	12.5	20	88
	—	130	70	60	32	16	26	98

¹⁾ Larger size may be required for optional equipment.

²⁾ Line current is referred to nominal input voltage of 230 VAC.

³⁾ Weight is referred to thyristor-controlled rectifier on a mounting plate without enclosure.



Enclosures

wall-mounted enclosure designation	weight (empty) [kg]	height	width	depth
R2	9	300	380	210
R3	12	380		
R4	17	600		
R4+	26	600	600	350
R4T	22	380		
R5	31	600		
R5+	38	760		

floor-mounted enclosure designation	weight (empty) [kg]	height*	width	depth
R6	66	1200	600	400
R6+	80		800	
R7	127	1800	600	
R7+	150		800	
R8	147	2000	600	500
R8+	175		800	
R9	250		1200	

*) The height of the base frame, elevated roof and suspension eyes is to be added, if needed.

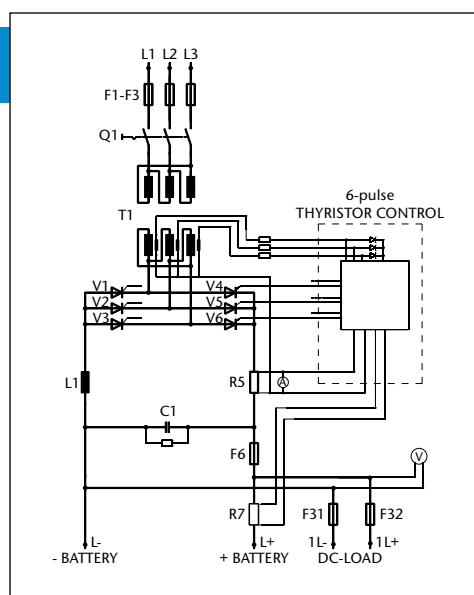

Model designation (example): QD 60 / 32

three phases input
 nominal output voltage [V]
 max. output current [A]

QD - Series

3-phase thyristor-controlled rectifiers, 1-500kW					
nominal output voltage					
24V	48V	60V	110V	220V	360V
max. output current					
from 0 to 3250A					

enclosure size ¹⁾	nominal output voltage					approx. line current ²⁾ [A]	approx. weight ³⁾ [kg]
	24 V	48 V	60 V	110 V	220 V		
R4	25	12	10	5	2.5	1.1	48
	40	20	16	8	4	2	62
R5	60	30	25	12	6	3	74
	80	40	32	16	8	4	78
R5+	100	50	40	20	10	5	85
	125	60	50	25	12	6	95
R6	160	80	65	32	16	8	130
	200	100	80	40	20	10	150
R6+	240	120	100	50	25	11	180
	300	150	120	60	30	14	260
R7	350	170	140	70	35	16	310
	400	200	160	80	40	19	340
R7+	500	250	200	100	50	24	390
	600	300	240	120	60	28	420
R8	700	350	280	140	70	33	450
R8+	800	400	320	160	80	38	510
R9	1000	500	400	200	100	48	620
2 x R8+	1200	600	500	250	120	57	680
	1600	800	600	300	150	76	740
	2000	1000	800	400	200	95	780
	2250	1125	900	500	250	120	920
	2750	1375	1100	600	300	142	1000
2 x R9	3250	1625	1300	700	350	166	1180
	—	1800	1450	800	400	190	1300
	—	2250	1800	1000	500	238	1450
3 x R9	—	—	2750	1500	750	356	1630
	—	—	—	2000	1000	475	1875
4 x R9	—	—	—	—	2000	950	2390

¹⁾ Larger size may be required for optional equipment. Enclosures see page 111.

²⁾ Line current is referred to nominal input voltage of 3 x 400 VAC.

³⁾ Weight is referred to thyristor-controlled rectifier on a mounting plate without enclosure.



Schaefer offers the industry's most complete range of input and output voltages, combined with a selection of package style, mounting solutions, options for input and output as well as various possibilities of programming & monitoring.

Configuration of model designation:
Add the designation of options to the type number of the power supply module, e.g. C 3674-w-dr-eu1.



Input

<p>i inrush current limiting</p> <p>A thermistor is connected in series with the input lines which changes its resistance from high to low when it gets hot. It does not reduce the surge current if the input power is interrupted for a short period of time not allowing the thermistor to cool down. Thermistors are fitted as standard to all mains input models except for 1-phase input of models > 2.5 kW. Thermistors are available up to 45A. For higher input current an electronic inrush current limitation can be offered.</p>	
<p>ie electronic inrush current limiting</p> <p>An electronic circuit limits the high inrush current caused by built-in capacitors. Switch-on time may increase to 5s. This is realized by a series pass transistor or depending on the input voltage by thyristor softstart.</p>	
<p>sd reverse polarity protection for DC input by series diode</p> <p>A series diode protects the module against DC input voltage of wrong polarity. However, this also causes extra losses and reduces the overall efficiency. calculation formula: $I_{Diode} = 2 \times P_{out\ max} / U_{in\ min}$</p>	

<p>ad reverse polarity protection for DC input by anti parallel diode</p> <p>To avoid the power losses a diode is provided with opposite polarity in parallel to the input blowing an internal or external fuse if the module is connected to a supply of wrong polarity. calculation formula: $I_{Diode} = 2 \times P_{out\ max} / U_{in\ min}$</p>	
<p>au auto-ranging</p> <p>For standard dual AC input models the range of 115 / 230 V AC is to be selected by connecting the input line to different pins on the connector. With auto-ranging the unit senses the input voltage and provides automatically the correct connection.</p>	

Output

Parallel / redundant operation for DC output (details see page 125/126)

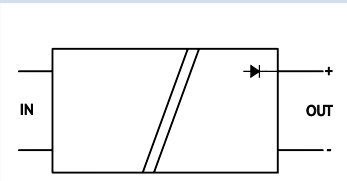
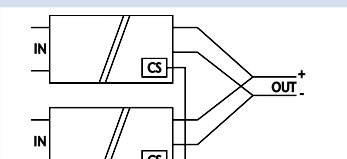
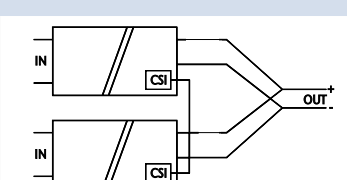
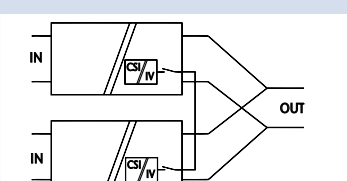
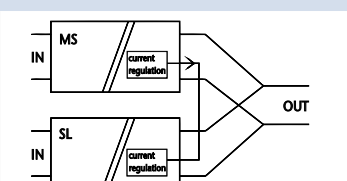

<p>dd decoupling diode</p> <p>A series diode built into the units output allows paralleling of 2 or more units for redundancy or higher power or battery charging. For control purposes the anode of the diode is also available at the output connector. It cannot be loaded $\geq 0.5A$. The sense signal is taken partially from the anode and partially from the load/cathode of the decoupling diode. This guarantees starting and operating under all conditions, but it also effects the regulation accuracy of 2%. In this way it gives a load sharing of 15-30% between the paralleled units.</p>	
<p>cs active current sharing</p> <p>An additional control circuit provides active current sharing via an interconnecting wire between converters that operate in parallel. The output lines of the converters have to be in "star point" connection.</p>	
<p>csi current sharing interrupt ("cs" included)</p> <p>"csi" will effect the removal of the "cs" signal from the load voltage common connection. Should there be an instance where a unit is not supplying the load, then the effect of its current sharing signal is removed, and the load voltage is unaffected by this condition. In terms of calibration the same criteria follow as for parallel operation.</p>	
<p>icsi current sharing interrupt ("csi" included), galvanically isolated</p> <p>The inclusion of "csi" (current sharing interrupt) and the galvanic isolation is the optimum set up for systems with high power or high currents, were the voltage drop on the power wiring could influence the cs signal.</p>	
<p>ma master / slave operation (available for series 6xxx)</p> <p>Master / Slave interface permits the parallel function of identical modules to increase the output power capacity, shared by current control without any dynamic reduction in performance.</p>	

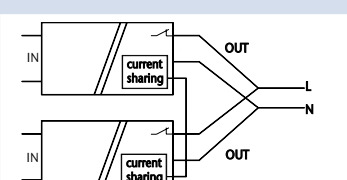
Parallel / redundant operation for AC output

<p>red inverter parallel operation: for series IT5xxx</p> <p>For redundant operation or for increased output power, two inverters of the IT5xxx series can be switched together. If one inverter fails, the internal contactor will be switched off and the output power of one inverter is still available.</p>	
---	--

General information

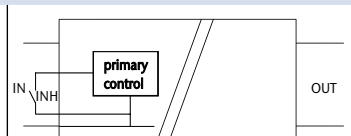
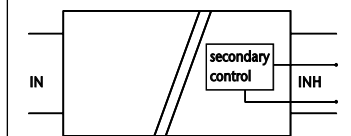
The number of options per module may be restricted due to limitation of space inside the module or due to a limited number of connector pins. Potentiometers or interface cards may be supplied separately for installation outside of the module.

<p>Inhibit</p>	
<p>h1 inhibit by external closing contact, signal referred to input</p> <p>The operation of the unit is inhibited when a voltage signal is applied in reference to the negative line of the input. This can also be used in combination with a thermal trip, which shuts the unit down.</p>	
<p>h2 inhibit by voltage signal, signal referred to output</p> <p>Operation of the unit is inhibited if a voltage signal (5V / 10mA) is applied in reference to the negative line of the output.</p>	
<p>h3 inhibit by closing contact, signal referred to output</p> <p>The operation of the unit is inhibited when a voltage signal is applied in reference to the negative line of the output. This can also be used in combination with a thermal trip, which shuts the unit down. Please note: Only relevant solution for inverters.</p>	

Automatic reduction of current limiting

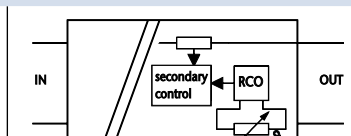
<p>rco reducing current limiting at over temperature</p> <p>A circuit reduces the current limiting level at higher temperature (to be specified). Please note: Option is available for series 48xx with ZVS topology and for high power converter modules (see page 49).</p>	
---	---

DC output protection

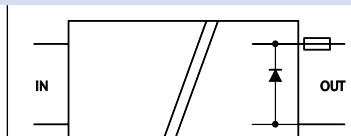
<p>rd reverse polarity protection for DC output</p> <p>by reverse diode with external fuse</p>	
---	---

Signals

pr	input voltage supervision (power ok) incl. relay contacts A logic signal is given if the input voltage (AC or DC) drops below the specified limit. In AC input models the rectified input voltage is sensed so that a power fail alarm can be avoided if at light load mains power returns before the input capacitors are substantially discharged. A relay contact is provided for failure indication.	
dr	output voltage supervision (DC ok) incl. relay contacts A logic signal is given if the output voltage is below the specified limit. A relay contact is provided for failure indication. DC ok level: 5V output: 4,75V all other voltages: 90% of adjusted voltage	
cf	charger / converter fail supervision incl. relay contacts A logic signal is given if the input voltage, the auxiliary voltage of the primary side and the current of the primary side exceed or go below a specified range. A relay contact is provided for failure indication.	
ac	AC ok for inverter including relay contacts A logic signal is given if the output voltage of an inverter is below the specified limit. A relay contact is provided for failure indication.	

General information

The number of options per module may be restricted due to limitation of space inside the module or due to a limited number of connector pins. Potentiometers or interface cards may be supplied separately for installation outside of the module.

Programming

Converter Programming	
	programming of output voltage from 0 to 100 %
eu1	by external signal, 0 – 10 V
eu2	by external signal, 4 – 20 mA
eu3	by 270° potentiometer
eu4	by 10 turn potentiometer
	programming of output current from 0 to 100 %
ei1	by external signal, 0 – 10 V
ei2	by external signal, 4 – 20 mA
ei3	by 270° potentiometer
ei4	by 10 turn potentiometer
iso	isolating amplifier for programming Programming signal is galvanically isolated from any potentials of the power supply.
	programming via
rs	RS232 (external)
can	CAN Bus (external)

Charger Programming	
	temperature features
tc	temperature compensated charging voltage (sensor not included)
ts1	temperature sensor not interchangeable due to fixed resistor values
ts2	temperature sensor interchangeable, IC controlled
	charging characteristics
ch1	External card: automatic and manual selection of charging characteristic (float/ equalized boost charge) with timer (delayed return to normal operation), including aux. supply and options "tc" and "ts1"
ch2	External card: consisting of option "ch1" plus: Battery current limitation & battery shunt
ch3	External card: consisting of option "ch2" plus: CAN-Bus-interface & programmable parameters

Monitoring

Converter / Charger Monitoring	
	monitoring of output voltage from 0 to 100 %
mu1	by external signal, 0 – 10 V
mu2	by external signal, 4 – 20 mA
	monitoring of output current from 0 to 100 %
mi1	by external signal, 0 – 10 V
mi2	by external signal, 4 – 20 mA
iso	isolating amplifier for monitoring Monitoring signal is galvanically isolated from any potentials of the power supply.
	monitoring via
rs	RS232 (external)
can	CAN Bus (external)

Mechanics

As standard, all of the modules are designed and manufactured for insertion into 19" sub-racks. Higher power modules are already constructed in 19" format.

Optionally, 19" sub-racks are available and can be configured as 3U or 6U allowing any mix of units and can be upgraded in accordance to the customers' requirements, e.g.

- mating connectors wired to a terminal block
- fuses or circuit breakers
- hot swappable configuration upon request
- analog or digital meters
- switches
- fans
- filters
- decoupling diodes
- provisions for keying the modules to ensure module / slot designation



19" Sub-Racks

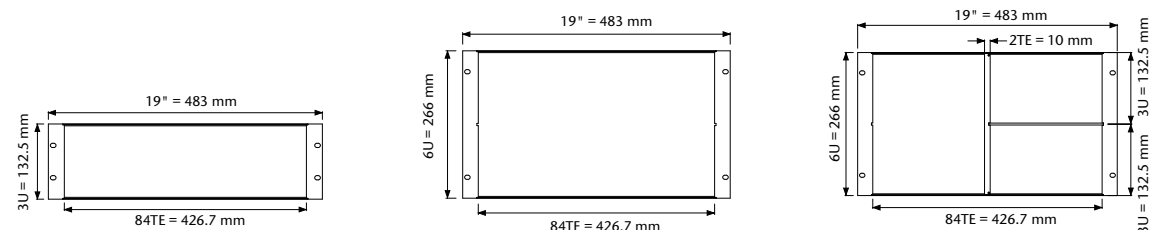

w wall mount

Modules, which have the wall mount option, are typically fixed to a structure or within a cabinet. Depending on the size of the module, this may be done with a flat or angled plate (see photo). The load connections are typically through a terminal block. Should the application not require a pluggable module / rack solution, wall mounting presents an alternative option for the customer to choose from.



cha chassis mount

Module is designed for installation to a structure or within a cabinet. Screw type mating connectors are supplied with the module. Due to the limited number of connector pins this option is not available for modules with dual AC input. Option is available for currents up to 60Amps.



din DIN rail mount

Module is designed for DIN rail mounting to a structure or within a cabinet. Screw type mating connectors are supplied with the module. Due to the limited number of connector pins this option is not available for modules with dual AC input. Option is available for currents up to 60Amps.

Environment

t tropical protection

The unit is given additional protection by a heavy coat of varnish on the printed circuit board(s) and on components to achieve 99% RH, non condensing.

c extended temperature range

The circuit is designed and tested for operation at an ambient temperature as low as -40°C.

ms increased mechanical strength

Screws are secured with Loctite and heavy components are fastened by ties and / or glue. Modules with the „ms“ are build acc. to EN 61373 regarding shock and vibration.



Control & Monitoring



TC 01 Control function
 analogue or micro-processor-controlled supervision:

- input voltage
- output voltage
- battery circuit
- ground insulation failure
- over temperature

UC 03 Enhanced controller function

The „UC 03“ unit controls and supervises the optimum charging of a battery, up to an entire UPS system. A battery charging in a basic way, with a switch mode AC / DC or DC / DC Charger, is shown in the following figure.

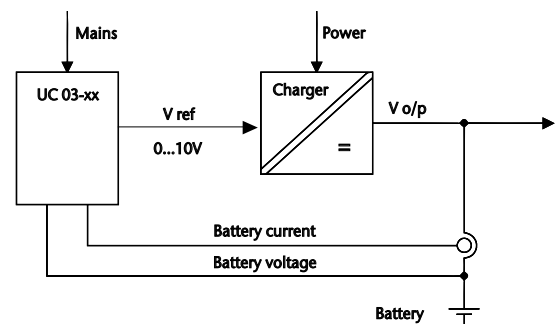

The charger output voltage is regulated inside the charger according to the input "Vref" signal. The gain factor between Vref and Vo/p is defined in the Specification of the Charger. The charger current limitation is also a function of the charger. The reference values, limitations and monitoring levels for charging a battery (ies) are configurable in the UC 03. The charging of the battery occurs according to the current / voltage characteristics, i.e. the battery is loaded in current limitation, until the appropriate voltage is reached. The following working conditions are processed by the UC 03:

- a. Float Charge conforms to the recommended permanent voltage to hold the battery within a completely charged state.
- b. Equalize or Automatic Boost Charge: To charge the battery after a partial or deep discharge as quickly as possible, an increased voltage is provided. This mode is activated automatically via different functions, or manually via the front panel button.
- c. Manual Boost Charge: independently adjustable voltage, to regenerate an aged battery. In all three working conditions the maximum battery charge current is limited.



The following technical notes contain important information about various operating possibilities and circuitries as well as instructions that should be followed during installation etc. For further information please contact the SCHAEFR Team.

Parallel / Redundant System	I25
AC or DC input	I27
DC output	I28
AC output	I29
DC output voltage stabilization	I30
Mounting & Installation	I31
Connectors	I32
Basic Topologies	I33



Parallel / Redundant System

<p>Parallel operation</p> <p>Single output modules of the same voltage / power rating can operate in parallel under specific conditions. The output voltage can be carefully adjusted to be near identical. When there is sufficient loading on the combined output, all units will be active and supply the load. The load demand must be significant enough for the multiple units to deliver output current.</p>	
<p>Redundant operation</p> <p>The inclusion of the option "dd" (decoupling diode) on the output of the units will permit parallel operation, where the inability to provide output from one unit will not have a negative effect on the load provision. The decoupling diode will also result in a load regulation value, which, as a percentage of the output voltage, will be unit / output dependent. In terms of calibration the same criteria follow as for parallel operation.</p>	

<p>Balanced current operation</p> <p>The inclusion of the option "cs" (current sharing) allows for parallel operation with a significant degree of current balancing. The communication between the units allows for a voltage setting correction, which in turn shall equate to an automatic current sharing (balancing) on the outputs. The tolerance of such balancing is module dependent. In terms of calibration the same criteria follow as for parallel operation.</p>	
<p>Redundant balanced operation</p> <p>The inclusion of both, the "cs" and "dd" option results in an optimized balanced current provision while being de-coupled from each other. A connected module, who is not supplying an output voltage, will influence the load voltage. The voltage may be reduced by up to 7%. In terms of calibration the same criteria follow as for parallel operation.</p>	
<p>Fault tolerant operation</p> <p>The inclusion of "csi" (current sharing interrupt), "cs" and "dd" is the optimum set up for a fault tolerant application. "csi" will effect the removal of the "cs" signal from the load voltage common connection. Should there be an instance where a unit is not supplying the load, then the effect of its current sharing signal is removed, and the load voltage is unaffected by this condition. In terms of calibration the same criteria follow as for parallel operation.</p>	

AC or DC input

Inrush current	When the module is connected to the input power, the primary capacitors will be charged by a high current pulse. The magnitude of this pulse depends mainly on the input supply system. With a thermistor (temperature dependent resistor) in series with the input, this current pulse can be reduced, as the thermistor has a relatively high value of resistance as long as it is cold. This resistance becomes very low as the thermistor heats up. If the input power is interrupted for a short period of time not allowing the thermistor to cool down, and the primary capacitors are discharged, the current limitation function of the thermistor will not be effective. The thermistor is standard on mains input models up to 45 Amps input current. For higher input current there are two further alternatives available: Schaefer PFC or an electronic current limitation.
Power factor correction (PFC)	Power supplies draw line current in pulses from the input supply. Should it be required, a PFC will integrate these pulses to be both, effectively sinusoidal in shape, and in phase with the AC input supply. The result of this integration, be it active or passive, is the reduction of the harmonic distortion and allows a more effective loading of the input source.
Spike suppression	High input voltage spikes generated in the supply system that could disturb operation of the unit or cause damage will be absorbed by a varistor across the input lines.
Input under and over voltage turn off	The input voltage range of the unit is defined as the voltage limits at which it will operate. Should the input be reduced to a specific voltage, the unit will turn off by switching off the power circuit. The same applies to an increase in the input voltage. Once a preset value is reached then the power circuit will be switched off. It must be considered that the switching off of the power circuit does not mean a removal of the input circuit from the power supply.
Thermal shutdown with auto restart	The higher power Schaefer modules are fitted with a thermal shutdown. In the event of a temperature rise above a preset value, the unit will turn off. This safety feature will then remain active until the point of temperature measurement has reduced significantly. The time duration for this to be reached is dependent upon the environment and level of cooling.
Temperature derated load	It is the responsibility of the client to reduce the loading of the Schaefer product with respect to the temperature (derated load: 2.5 % / °C from +55 °C operating temperature). The maximum operating temperature of +75 °C must lead to the unit being switched off.
Efficiency	The optimum efficiency is obtained through a high input voltage measured against a high output voltage at maximum power rating.

DC output

Soft start	The application of the input power permits the unit to generate a secondary output. The switching on of the primary power circuit is controlled and gradually increased to allow a controlled charging of the secondary capacitors. The time duration for the secondary capacitors to be charged is defined as the soft start.																										
No load operation	Single output converters require no minimum load for operation within tolerance. Multi output converters require the main output be loaded. Semi-regulated auxiliary outputs may also require a minimum load to be applied.																										
Short circuit protection	The main output of a converter will be immune against a momentary or continuous short circuit. The secondary current limitation will not permit the sustained output current to be higher than the calibrated setting, and it will actively reduce the output voltage in accordance to the overload. The removal of the overload / short circuit will result in the output voltage being increased to the calibrated value. Regulated auxiliary outputs will also reduce the output voltage / current in accordance to their overloading. The characteristic may vary according to the circuit employed.																										
Over voltage protection (OVP)	The main output voltage is measured, either internally or through sense leads. This measured value is compared against a calibrated value. When the calibrated value has been reached, this circuit turns off the primary power circuit. Once the measured value has reduced below the calibrated value, the primary power circuit is permitted, once again, to be activated. The high power units have an additional feature, which will shut down the primary power circuit after a continued OVP operation. The input power must be re-cycled in order to remove the unit from shut down.																										
	<table border="1"> <tr> <td>voltage adjustment [V]</td> <td>5</td> <td>9</td> <td>12</td> <td>15</td> <td>24</td> <td>28</td> <td>48</td> <td>60</td> <td>110</td> <td>200</td> <td>220</td> <td>400</td> </tr> <tr> <td>Over voltage protection [V]</td> <td>6.5</td> <td>12</td> <td>15</td> <td>18</td> <td>30</td> <td>35</td> <td>60</td> <td>70</td> <td>140</td> <td>220</td> <td>280</td> <td>440</td> </tr> </table>	voltage adjustment [V]	5	9	12	15	24	28	48	60	110	200	220	400	Over voltage protection [V]	6.5	12	15	18	30	35	60	70	140	220	280	440
voltage adjustment [V]	5	9	12	15	24	28	48	60	110	200	220	400															
Over voltage protection [V]	6.5	12	15	18	30	35	60	70	140	220	280	440															
Sense leads	Through the use of sense leads, an output voltage may be regulated to a point outside of the unit. The sense leads should be connected to the power connection at the point of load under regard of polarity. There should be a non-interruptible connection between sense and load points. Interruption may lead to damage or the activation of the OVP circuit. The units, which have sense leads, have the ability to regulate to a higher voltage at the output connection. This increase is largely dependent upon the unit. The details may be found in the respective unit specification. Parallel operation with sense leads allows a common point for the units to regulate their voltages to. Units whose output voltage has been calibrated to be near identical will now be able to supply a common load. De-coupled outputs will be sensed both, before and after the decoupling diodes, which in turn will lead to an output voltage regulation, specific to load and unit. Sense leads are typically employed with a decoupled output voltage of less than 40 VDC. The current sharing option will effectively override the sense lead output voltage setting, but the point at which the output voltage is regulated, will be the point of sense lead connection.																										

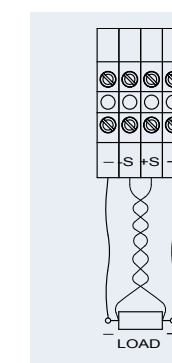

AC output

Soft start	The application of the input power permits the unit to generate an AC output. The output power increases linearly until it reaches its calibrated value. This delay from initial output generation until the nominal value is defined as the soft start.
No load operation	Inverters require no minimum load for operation within tolerance.
Short circuit protection	The inverter current limitation circuit provides a protection against an external short circuit. Due to the need for crest factor and pulse power requirement in many applications, the current limitation permits twice the nominal output current to be extracted for up to 1 second. The current limitation will then be reduced to typically 105% of the nominal value. Should the overloading persist, and the output voltage reduce to less than 20% of nominal, then the unit will perceive an overload condition and turn off. Recycling the input voltage will remove this latched off condition.
Crest factor	The ability of an inverter to deliver to a load an inrush current is related to the crest factor. The crest factor is the ratio between the nominal and the peak current.
Over voltage protection (OVP)	The high power units have this feature. It will shut down the primary power circuit after a continued OVP operation. The input power must be re-cycled in order to remove the unit from shut down. The output voltage is measured internally. This measured value is compared against a reference value. When the reference value has been reached, this circuit turns off the power circuit. Once the measured value has reduced below the reference value the power circuit is once again permitted to be activated.
Sense leads	Sense leads are internally connected in all standard configurations.
Harmonic distortion	The generated inverter output is designed to follow a true sine wave signal. Deviation from this sine wave is measured as distortion. The level of deviation is defined as harmonic distortion. The total harmonic distortion THD is the relationship between the harmonic and fundamental wave forms.
Surge power	The AC output may facilitate the output load through its ability to provide more than the nominal current for up to 1 second.
Power factor	The AC output may facilitate complex or other loads, through its ability to provide a phase shifted output current at nominal power rating. This is once again due to the ability to provide more than the nominal output current for a limited period of time.

DC output voltage stabilization

The output voltage of a battery charger with parallel connected batteries varies substantially with the charging condition of the battery. For many applications, however, the load circuit requires a more stabilized voltage which can be accomplished by:

Voltage dropping diodes

being interconnected between battery and load, reduce the voltage to a value suitable for the load. They are short-circuited by one or more contactors only if a partial reduction or no voltage reduction is required. A control circuit senses the battery voltage and energizes the contactors. Voltage dropping diodes cause substantial power losses as the excess voltage is absorbed by the diodes. However, due to simplicity, this method is frequently used, especially if the voltage reduction is needed only during the short periods of high-rate charging.

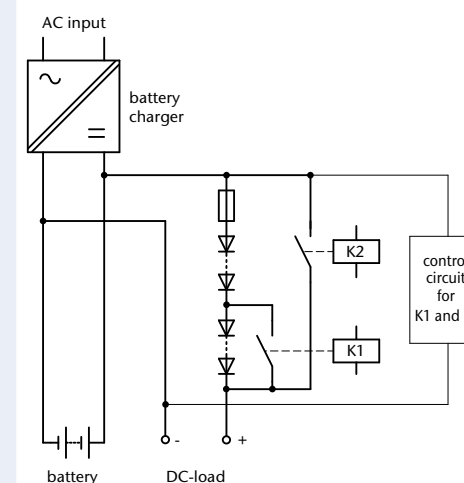

Switchmode step-up converters

are DC/DC converters supplied from the battery with the output connected in series to the battery. They present a very economical solution as they only add voltage when the battery is discharged. *Details see page 47/ 83.*

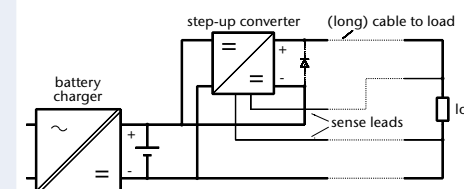

Mounting

Air flow

Airflow to the power supply is preferred to be filtered, below 55°C, an airflow resistivity (pressure drop) of below 20kPa and is required to comply with the EN60950 pollution category II. Diffused thermal energy is required to be exhausted and displaced by air as detailed above. Thermal management is required where the air provided to a power supply complies with the power supply's design parameters. The use of fans requires the increase airflow rate to a minimum of 120m³/h (corresponding to 70 cfm). The airflow resistivity and respective pressure drop should be considered when the fan is required.

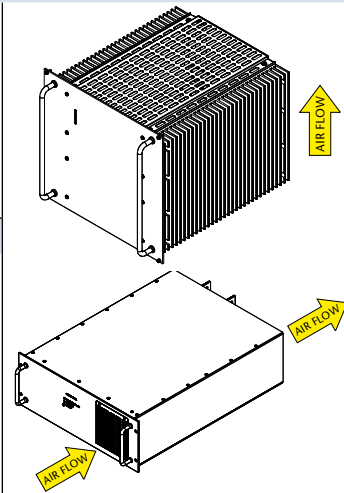

Direction of air flow

Typically, Schaefer Modules and systems are cooled through air supply entering below and exiting above, with the exception of models of series C/B 5100, 5200, 5300, 5400, 6400 and 6600 whose airflow is from front to back.

Custom design also offers lateral cooling. Such details are however, project specific.

Cabinet

To enhance a module / system, a cabinet may be employed.

- This may be required to fulfil the increased IP / NEMA rating, due to a negative effect of the environment on the solution.
- Specifically, in an unclean, saturated, corrosive or otherwise aggressive air quality it may be required to employ a cabinet in combination with features such as hermetical closure and air exchange amongst others.
- The enclosure must be capable of sustaining the weight of the modules, specifically if module support rails are used.
- Stationary cabinets should be fastened to the ground.
- The centre of gravity must be as low as possible with portable systems.

Transportation of module

The grips on the front of the modules are to assist in module insertion into a sub-rack, and not for supporting the weight of the module.

Wall mount / chassis mount

Modules with a mounting plate or angle are designed for integration into the host equipment. They are not for employment outside of an enclosure.

Installation

Input fuse

An input fuse, internal or external, should be selected with a slow burn characteristic.

Sense leads

- The distance between the load connection and the module / system may result in a voltage drop between the output and the load connection. To compensate for a limited value of such a voltage drop, sense leads can be connected to the load under regard of polarity. The sense leads determine the point to which the voltage regulates. As the sense leads carry very low current, they are susceptible to noise pick up. Therefore, it is recommended that they are intertwined and if necessary shielded.

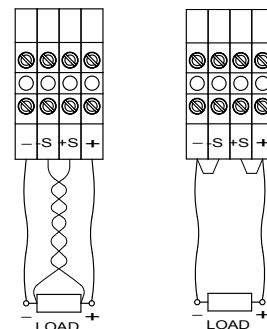

- When the remote sense facility is not used, sense links must be made at the output terminals. If the sense links are left open, the output voltage may rise causing the OVP circuit to be activated.

Connectors

H15 Female Connector

Number of contacts: 15
 Contacts: Fastons or screw terminals
 Operating current at +20 °C: 15 A
 Operating temperature: -55 to +125 °C
 Test voltage (contact to contact): 3100 V_{rms}
 Test voltage (contact to ground): 3100 V_{rms}
 Contact resistance: 8 mΩ
 Performance according to: IEC 60603-2 / DIN 41612

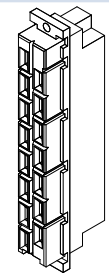

High Current Female Connector

Number of contacts: 2
 Contacts: Bolts with 8 mm diameter for terminal lugs M8
 Operating current at +20 °C: 170 A
 Operating temperature: -55 to +125 °C
 Test voltage (contact to contact): 500 V_{rms}
 Test voltage (contact to ground): 2500 V_{rms}
 Contact resistance: 0.06 mΩ
 Dimensions (H x W x D): 118 x 35 x 85 mm
 Performance according to: IEC 60603-2 / DIN 41612

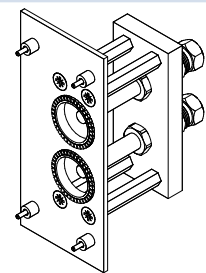

F24H7 Female Connector

Number of contacts: 24 / 7
 Contacts: solder pins / fastons
 Operating current at +20 °C: 6 / 15 A
 Operating temperature: -55 to +125 °C
 Test voltage (contact to contact): 1550 / 3100 V_{rms}
 Test voltage (contact to ground): 2500 / 3100 V_{rms}
 Contact resistance: 15 / 8 mΩ
 Performance according to: IEC 60603-2 / DIN 41612

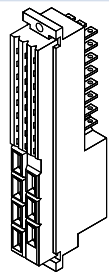

F48 Female Connector

Number of contacts: 48
 Contacts: solder pins
 Operating current at +20 °C: 6 A
 Operating temperature: -55 to +125 °C
 Test voltage (contact to contact): 1550 V_{rms}
 Test voltage (contact to ground): 2500 V_{rms}
 Contact resistance: 15 mΩ
 Performance according to: IEC 60603-2 / DIN 41612

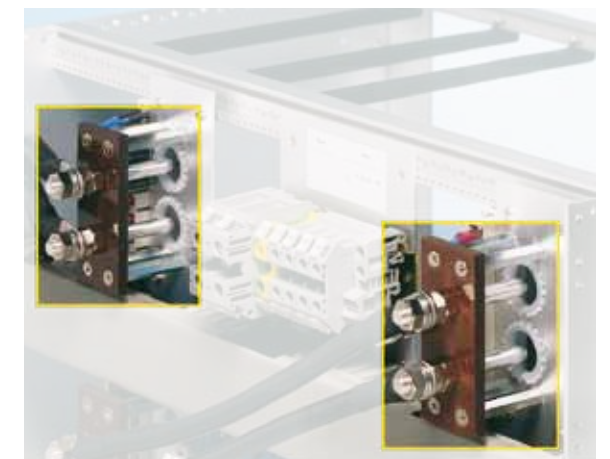
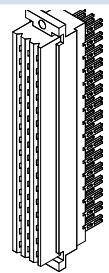

There are various circuit topologies and the selection depends on the requirements, such as low or high input voltage, low or high output voltage, single or multi output, power rating. The following circuits present our common concepts of power conversion.

Push Pull Converter

The push pull converter is often used for applications with low input voltage. The switching transistors are alternately conducting with variable pulse-width. At the secondary side, after rectification and filtering, the output voltage is sensed and compared with a reference. The error signal controls via an opto-coupler the primary circuit.

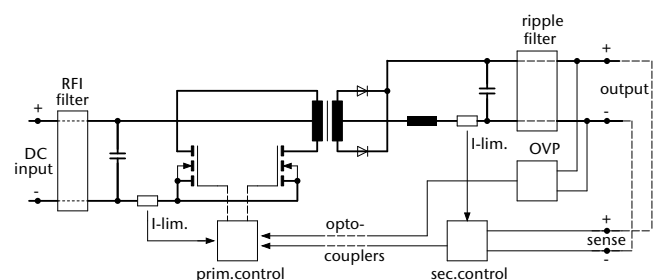

Half Bridge Converter

The following circuit shows, as an example, a converter with dual AC input in a half bridge connection. With the input voltage supplied to the 230 V terminal, the rectifier circuit is a standard bridge connection; supplied to the 115 V terminal the rectifier circuit functions as a voltage doubler circuit.

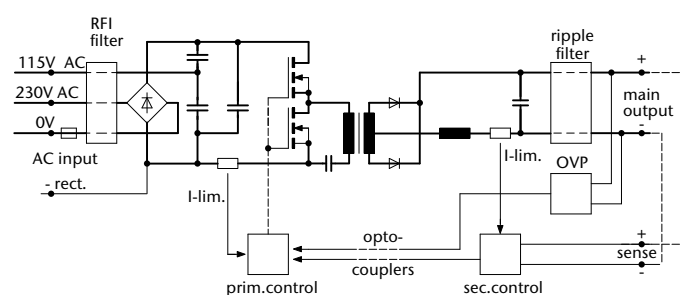

DC/AC Inverter

The diagram beside shows the circuit of an inverter. The DC input voltage is transformed by the power transistors T1-T4 with the parallel connected inverse diodes D1-D4 in a pulse-width modulated square wave voltage. The choke with the windings LI and LII integrates this voltage, and at the capacitor C a sinusoidal output voltage is available. The power transistors are controlled via opto-coupler in such a way that not both transistors of one branch are conducting at the same time. The output voltage is sensed and compared with a reference signal generating the firing pulses for the power transistors. The output current is measured via shunt R1 and limited through the control circuit. Isolation between input and output and voltage transformation can either be provided by a converter connected to the input of an inverter or by a transformer connected to the output of an inverter.

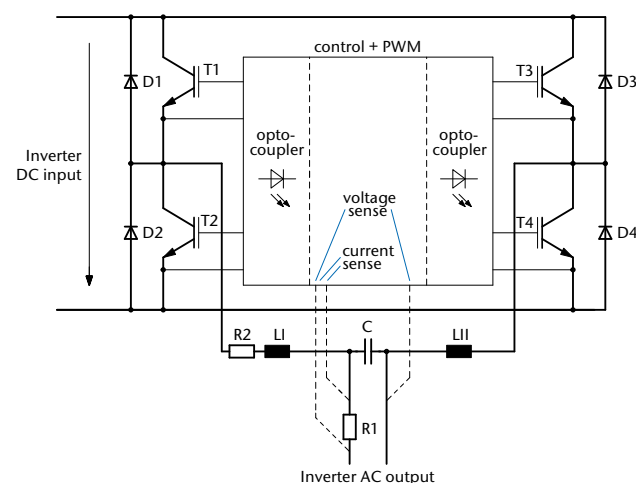

Full Bridge Converter with Zero Voltage Switching (ZVS)

For the higher power modules presented from page 46 to 67 the primary circuit is performed as a full bridge connection with four switching transistors (IGBTs) being controlled by the driver and protective circuits. The special mode of driving the IGBTs in conjunction with the resonant choke and the symmetrical capacitor allows for "zero voltage switching" which improves the efficiency and reduces the switching noise. The input can be designed for both, DC or AC. At the secondary side of the transformer the voltage is rectified and filtered. Then the output voltage is sensed and compared with a reference, and

the error signal controls via opto-coupler the switching transistors on the primary side. For over voltage protection the OVP circuit senses the output voltage and turns off the switching transistors if a certain level is reached. The circuit automatically returns to operation but is repeatedly switched off and turned on again if the over voltage condition is still present. If the unit does not return to normal operation within a short period of time, it will then be switched off. For current limiting the signal sensed by the LEM transformer starts to reduce the output voltage if the current exceeds a certain limit.

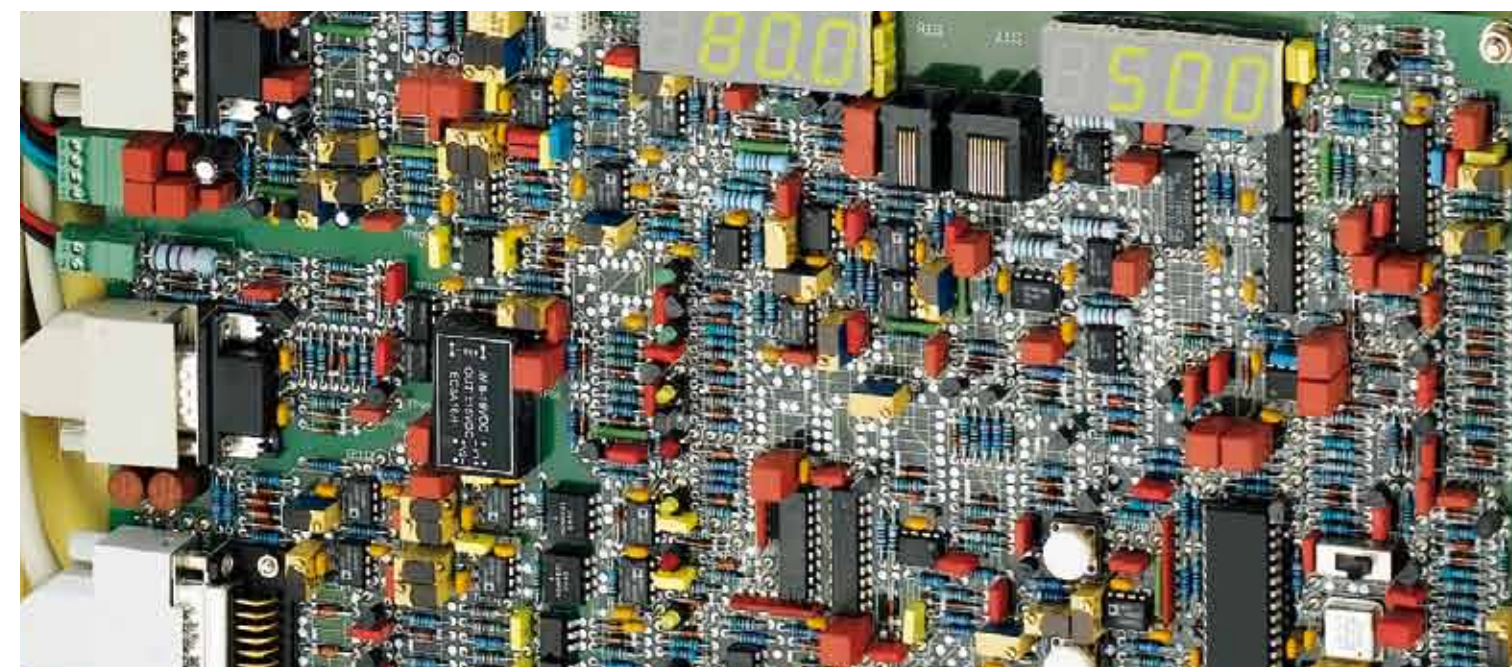
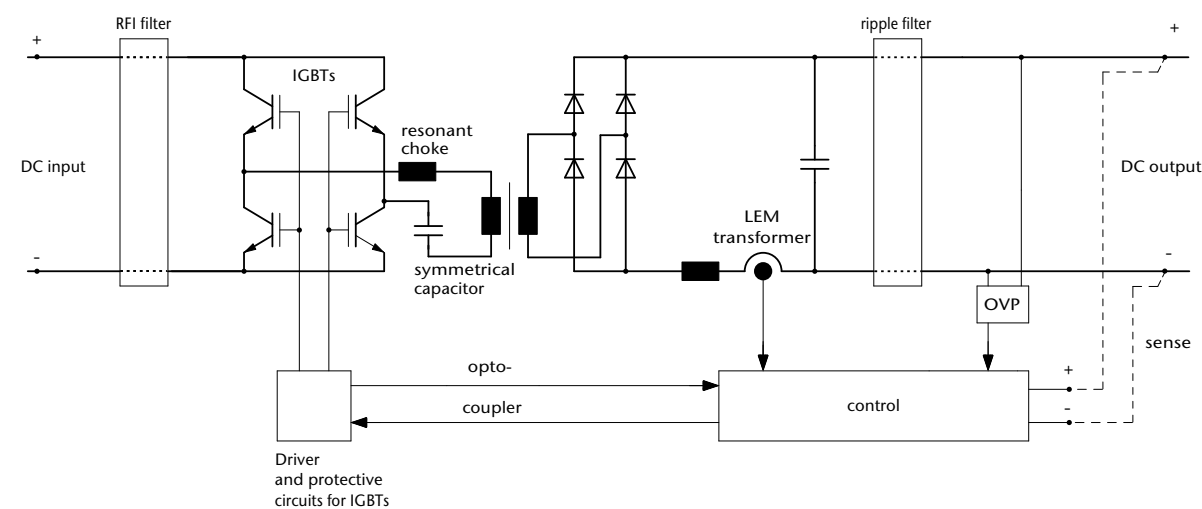

The distinction in the market of power supplies is achieved by being customer orientated, the unique variety of products available and the high level of flexibility to customer specific requirements as well as the modification of standard equipment for small and large quantities.

made in Germany



Interested in new projects?
Just scan this QR-Code!

Customization

Immediate proximity also generates the free flowing information path, which is the production and development areas, along with the testing and customer support areas being all under the same roof. This enhances the SCHAEFER Teams ability to react to exacting demands with ease. Fruits of this labour are to be seen throughout the World, in a variety of fields such as:

- Rail & Automotive Industry
- Power Generation Plants
- Oil & Gas Industry
- Chemical Industry
- Industrial Automation
- Military Industry
- Building Security
- Integrated Airport Solutions

Be they on shore or off shore, stationary or mobile, land, air or marine based. A system component or complete system, environmentally Hazardous area 1, corrosive or simply Industrial, there is a SCHAEFER Power Solution to fit the parameters.

Welcoming the challenge, the SCHAEFER Team offers the highest quality engineering designed and manufactured in Germany.

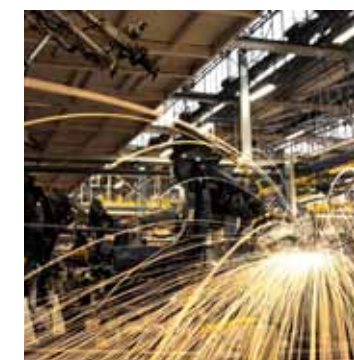



40kW On-board Power Supply System

- Multi input/ Multi output system
- Hermetically sealed enclosure
- Controlled air management
- Battery charger & DC Bus supply
- Challenging environmental specifications
- Engineered for high degree of shock & vibration
- Self-protecting, autonomous assessment of thermal and electrical parameters

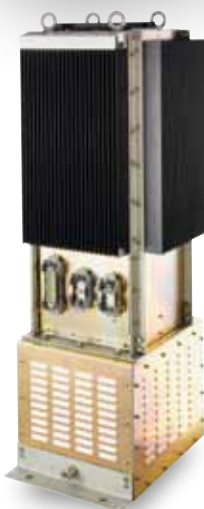

8kVA Rolling Stock Mounted Inverter, IP66

- Client specific interface connection
- Anchored to the RAIL Car floor
- 600mm x 600mm foot print
- Impervious to both impulses and spikes across the input, this module delivers the full output range with a crest factor of 3, up to +75°C environmental temperature
- Full power ability, across a phase shifted load, capacitive & inductive load tolerant of $\pm 0.7 \cos \phi$



300kW ultra fast charging station for E-Busses

- Modular and expandable power capability
- N+1 redundancy concept fully redundant and fault tolerant
- Easy system expandability up to 1MW by adding additional fully wired 100kW enclosures
- Output voltages available up to 1000 V
- Control and adjustability of electrical parameter
- Additional customised options CAN/ Modbus Interface



Coolant System Control for Reactor

- KTA 3507 certified
- Integrated switch mode Power Supply
- Reactor Core temperature evaluation
- High level of reliability, redundant fault tolerant capability
- 19" designed Rack mechanical solution
- Enhanced mechanical design
- Programmable output parameters through Client Interface



Power Supply Modules for Substations

- Fault tolerant power configuration
- Automated interrupt free by-pass operation
- Stabilized load feed
- Expandable to multiple redundant design
- Hot-pluggable
- Multiple mechanical solutions and styles

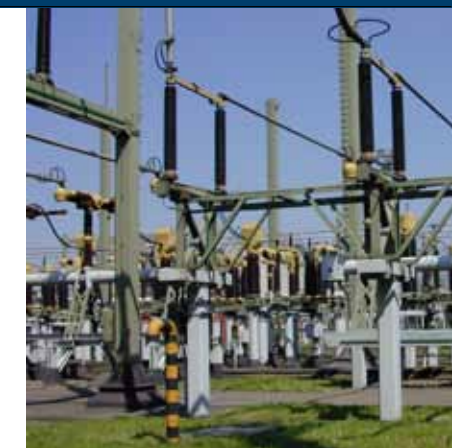

N+2 UPS System

- Configured both dual redundant & fault tolerant
- Supplied from multiple independent DC and an AC source
- Both automatically and manually operational by-pass system
- Integrated & isolated AC by-pass
- The indication panel reflects the operational status, while multiple stage monitoring is both locally and remotely communicated.

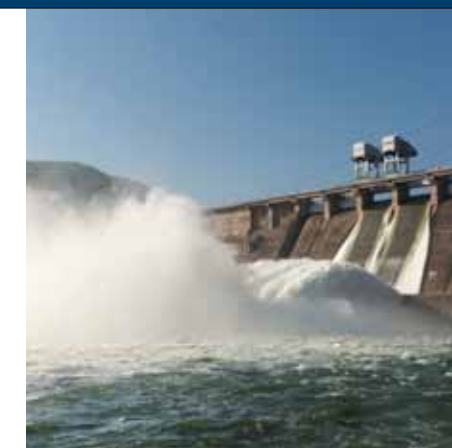



Subsea Power Supply

- Module based on a C3700 standard unit
- Extreme Environmental Challenges
- Wide range of AC input supply
- Robust heat sink design to integrate into the titanium pipe / tube
- Enhanced mechanical integration
- Over-temperature alarm
- The unit is given additional protection by heavy coat of varnish on the printed circuit board and on the components.



360kW expandable power supply system

- Mineral exploration on vessel:
- Assisting the oil industries in the search of oil reserves offshore via electromagnetic streamer process
- Liquid cooled current source up to 2500 A with high dynamic regulation properties
- Modular, N+1 redundant concept via 30 kW single modules with Master/ Slave configuration

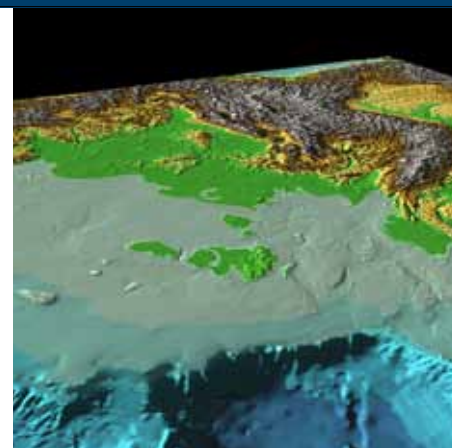
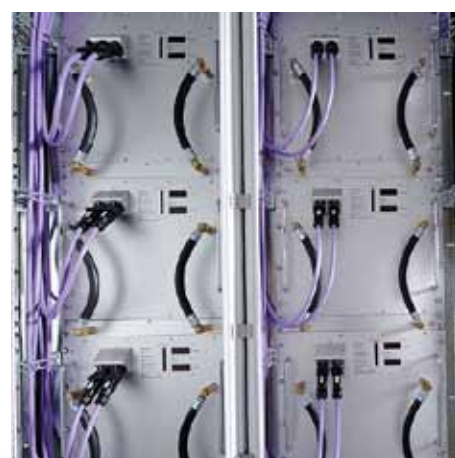

Power Supply for Off-shore Oil & Gas Industry

- 15kW liquid cooled power supply system
- Dimensions: 5U x 19" x 600mm deep solution (H x W x D)
- Redundant fault tolerant capability
- High efficiency through ZVS topology
- Assisting the industry in the search for mineral resources



On-board Military UPS

- Integrated Inverter, Static Switch and Battery Charger
- Dimensions: 6U x 19" x 500mm deep solution (H x W x D)
- Robust and reliable design
- Digital voltmeter display for DC input (battery voltage) on front plate
- Push button for "Latch Reset"
- Common alarm with relay contact
- Digital voltmeter display for DC input (battery voltage) on front plate



On-board 3-D Radar Power Supply

- AC/DC converter with fan cooling
- High level of reliability, Redundant fault tolerant capability
- Environmental adapted to 97% non condensing humidity
- Power Factor correction for three-phase input minimizing the load requirement of generator
- Client specific mechanical & electrical design with special heat sinks

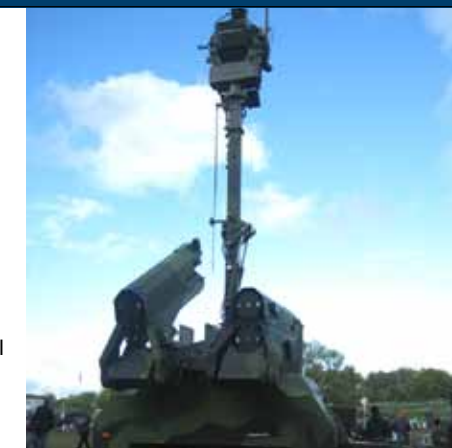

Integrated combined solution

- 5kW Modules ensuring a high power density
- Flexible orientation
- Capable of populating a 5U RACK with three units
- Capable of populating a 3U RACK with two units
- Engineered for high degree of shock & vibration



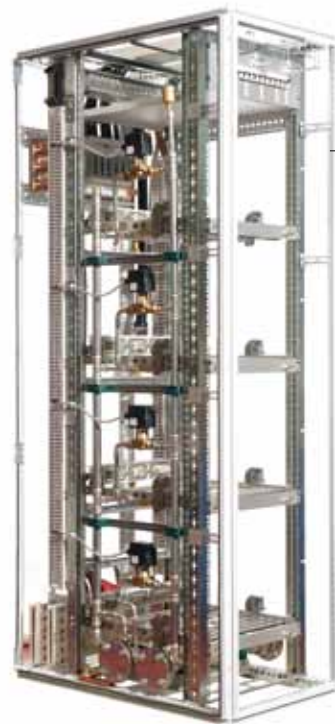

N+1 DC UPS System

- Configured as a redundant & fault tolerant solution
- Supplied from multiple independent AC sources
- Both automatically and manually operational output characteristic
- Compliant with exacting environmental standards to ensure a highly reliable load power supply for critical applications



7kW Power Supply for Security Checkpoints



- Airport application
- Wide input voltage range: 208 - 400V AC, 3-phase
- High output voltage: 600V DC
- Cooling via temperature controlled fans
- Industrial grade components
- 4U plug-in module



Worlds largest water fountain at Burj Khalifa, Dubai

- Charging the integral water, light and sound show of the fountain
- Turn-key customised design: UPS systems within a cabinet inclusive battery equipment as well as various SMPS systems
- Supervision and diagnostic software
- CAN/Ethernet interface for control and monitoring of electrical parameters



40kW Liquid cooled Power Supply

- For semiconductor manufacturing industry
- Highly demanding environment
- Extreme load variations
- Transfer of thermal energy into a fluid for heat exchange re-capture
- Programmable output parameters through Client Interface

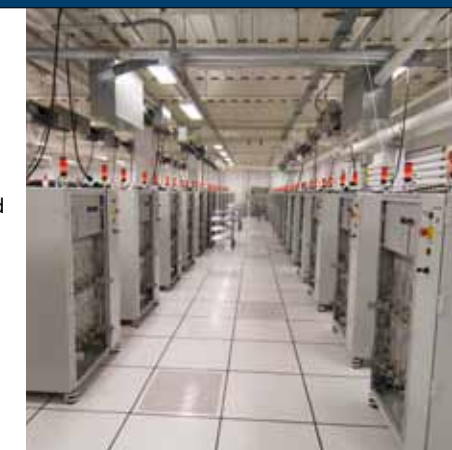

DC/DC Converter for Robotics Power Supply



- Wide input voltage range: 450 - 800V DC
- Multi output parameters
- Natural convection
- Remote on / off (inhibit)
- CAN-Bus interface
- High level of reliability, redundant fault tolerant capability



Digital controlled generator for Eroding Steel Rolls

- Electrical Discharge Generator with adjustable power source: 0-30A
- Synchronized output at $U_{out}=300V$ with adjustable frequency in the range of 200Hz to 300KHz
- Pluggable system, installation on water heat sinks via pressure rails
- Communication via EtherCat (PC-generator)





4kW Inverter System for Aircraft Mains Simulation

- Ground equipment for mains simulation on the Eurofighter
- Converter for 400Hz mains simulation
- Output selection, 3-phase AC or 3 individual DC voltages
- Each output is individually programmable via RS232 interface in voltage and frequency
- 400Hz Input Frequency

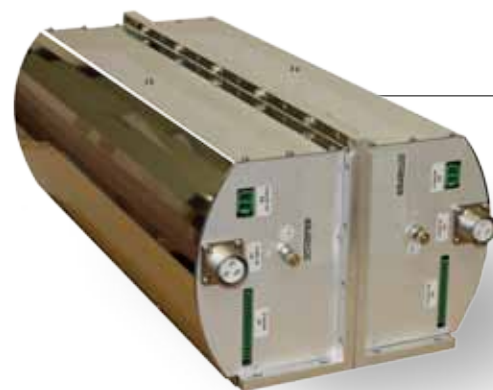

1kW N+I Tsunami Warning System

- Sub sea power supply
- Input voltage 1200V DC up to 2450V DC (nominal)
- Output voltage required, 380V DC (300 – 400V DC calibration range)
- Galvanic isolation
- High level of reliability

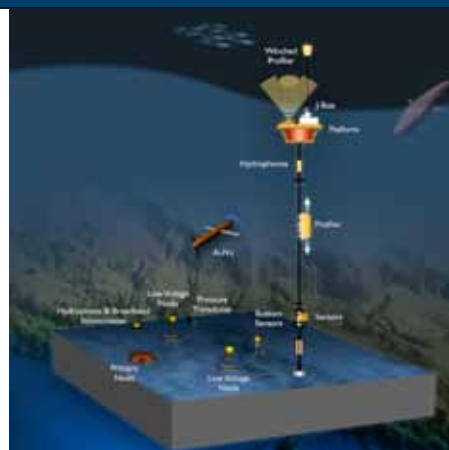

Safety Valve

- For installation in explosive environments (hazardous area 1)
- Allowing the failure of a single power supply, not affecting the controlled output
- The overall power supply unit is housed within a certified Exd enclosure
- An Exe enclosure being attached to the Exd enclosure contains all terminations, operator indications and switches



If you are lost on the moon, marooned in the ocean or just dealing with pollution, Schaefer has the POWER to find the solution.





A large grid of small dots for taking notes, consisting of two equal-width columns.

